

CAVERN - BASIC CAVE - CAVE

TRAINING...

IT STARTS WITH
YOUR COMMITMENT TO
LEARN AND RESPECT
YOUR LIMITATIONS.



NSS/CDS Training Chairman
Jim Wyatt
WWW.NSSCDS.ORG

CAVERN - BASIC CAVE - CAVE**CREDITS**

Covers-

Photos: Front &
Back Covers:

Kristi Bernot
Gene Page

Cover Design:

Kristi Bernot

Workbook

Graphics/Photos:

Henry Averill
Kristi Bernot
Denny Willis
NSS-CDS Library
LamarTek
OxyCheq

Editing:

Paulette Jones
Pete Butt
Reggie Ross
John P. Jones

Cartography-

As noted on maps.

Special thanks to the QRSS for maps of: Carwash, Chac Mol and Naharon

CAVERN - BASIC CAVE - CAVE

NSS-CDS TRAINING PROGRAM: PURPOSES AND GOALS

A. Primary purposes of The Cave Diving Section of the National Speleological Society (NSS-CDS) are to:

- Educate the general public in the proper procedures and techniques for participating in cavern or cave diving; formal training stresses the importance of cave conservation in addition to safe diving practices and procedures. The NSS-CDS believes that only with proper training and guided experiences can one visit underwater caves in a manner that reduces risk.
- Protect the caverns and caves from harm; We believe that a properly trained cave diver will significantly reduce the impact that can be caused to the cave environment and its unique features.

The NSS-CDS is committed to the safe and proper enjoyment of the cave environment and its protection.

B. The goals of the NSS-CDS Training Program include:

- Establish and maintain standards and procedures for the training of SCUBA divers in cavern and cave diving.
- Establish and maintain standards and procedures for the development of cavern and cave diving instructors.
- Develop and make available outlines and other educational support materials for cavern and cave diving training.

CAVERN - BASIC CAVE - CAVE

TABLE OF CONTENTS	Page
NSS-CDS ORGANIZATION	8
NSS POLICY FOR CONSERVATION	9
CAVERN TO CAVE DIVER ESSENTIAL INFORMATION	11
CONSERVATION	12
LANDOWNER RELATIONS	12
ACCIDENT ANALYSIS	14
PSYCHOLOGICAL ASPECTS & STRESS CONTROL	16
UNDERWATER CAVE FORMATION AND TERMINOLOGY	20
TYPES OF UNDERWATER CAVE ENTRANCES	22
GENERAL HAZARDS (OF THE ENVIRONMENT)	24
SPECIFIC HAZARDS (OF THE ENVIRONMENT)	24
NON-ENVIRONMENTAL HAZARDS	26
EQUIPMENT	28
TRIM & PROPULSION	30
GUIDELINES	30 / 58
DIVE TEAM PROTOCOLS	32
COMMUNICATIONS	36
DIVE PLANNING & PROCEDURES	38
PROBLEM SOLVING PROCEDURES	42
GAS SUPPLY MANAGEMENT & PROBLEM SOLVING	44
DECOMPRESSION CONSIDERATIONS	68
CAVERN DIVER	49
BASIC CAVE/INTRO CAVE DIVER	55
APPRENTICE CAVE DIVER	65
CAVE DIVER	79
UNDERWATER CAVE SURVEYING– AN INTRODUCTION	85
CONTINUING EDUCATION; SPECIALTY COURSES AND PROGRAMS	99
APPENDIX	105

THE NSS-CDS ORGANIZATION

The Cave Diving Section (CDS) is a non-profit general membership group founded in 1973. Our parent organization, National Speleological Society (NSS) was founded in 1941. Together we promote cave conservation awareness, cave diving safety and the study and exploration of underwater caves. Your membership and donations help us to continue to fund these and many other worthwhile endeavors. The NSS-CDS also purchases cave sites in order to protect open access for members. Joining the organization has many benefits, including;

- Publications such as Underwater Speleology and NSS News.
- Events such as the annual workshop.
- Access to CDS-owned dive sites.
- Access to technical and dive site information.
- A collective voice for concerned cave divers for cave conservation.
- Organizational status for seeking and maintaining access programs to cave sites on public and private lands.

Cow Springs



Cathedral

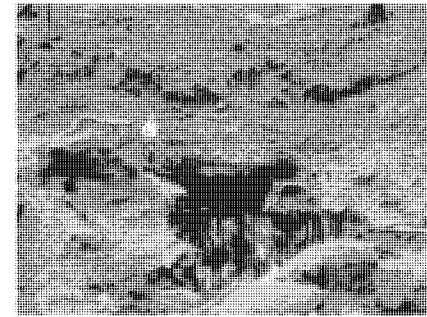

Wayne's World / School Sink



Mill Creek (Alachua Sink)

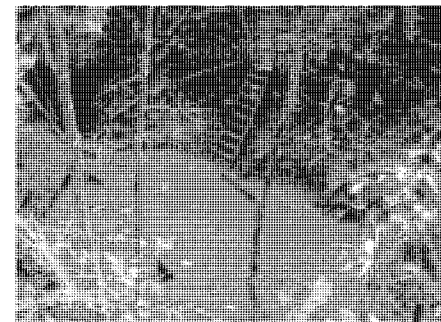

NSS POLICY FOR CAVE CONSERVATION

The National Speleological Society believes: that caves have unique scientific, recreational, and scenic values; that these values are endangered by both carelessness and intentional vandalism; that these values, once gone cannot be recovered; and that the responsibility for protecting caves must be assumed by those who study and enjoy them. Accordingly, the intention of the Society is to work for the preservation of caves with a realistic policy supported by effective programs for: the encouragement of self-discipline among cavers; education and research concerning the cause and prevention of cave damage; and special projects, including cooperation with other groups similarly dedicated to the conservation of natural areas.

Specifically:

All contents of a cave; formations, life, and loose deposits are significant for its enjoyment and interpretation. Therefore, caving parties should leave a cave as they find it. They should provide means for the removal of waste; limit marking to a few small and removable signs as are needed for surveys; and especially, exercise extreme care not to accidentally break or soil formations, disturb life forms, or unnecessarily increase the number of disfiguring paths through an area.

Scientific collection is professional, selective and minimal. The collecting of mineral or biological material for display purposes, including previously broken or dead specimens, is never justified, as it encourages others to collect and destroy the interest of the cave.

The Society encourages projects such as: establishing cave preserves; placing entrance gates where appropriate; opposing the sale of speleothems; supporting effective protective measures; cleaning and restoring over-used caves; cooperating with private cave owners by providing knowledge about their cave and assisting them in protecting their cave and property from damage during cave visits; and encouraging commercial cave owners to make use of their opportunity to aid the public in understanding caves and the importance of conservation.

Where there is reason to believe that publication of cave locations will lead to vandalism before adequate protection can be established, the Society will oppose such publication.

It is the duty of every Society member to take personal responsibility for spreading a consciousness of cave conservation awareness to each potential visitor of caves. Without this, the beauty and value of our caves will not long remain with us.

CAVERN - BASIC CAVE - CAVE

CAVERN-CAVE DIVER

ESSENTIAL INFORMATION

CONSERVATION

The concept of “Cave Diving Safety” does not just concern diver safety, but also the impact on the cave system that we choose to enter.

- A person selects and enters a cave by choice; the cave cannot discriminate between the trained or untrained, the careful or careless, and the respectful or reckless.
- Leave the cave as it was found; refrain from casual collecting of any kind.
- Make sure your skills are matched to the cave you are diving.
- Attempt to remove trash when possible and leave none of your own.
- Do not damage or otherwise disturb the cave; your impact will be visible for thousands of years to come.
- Develop an awareness of sensitive cave structures and features.
 - Goethite/ phreatite formations.
 - Sediment formations / Clay Banks.
 - Delicate formations.
 - Cave fauna and bacteria colonies.
 - Speleothems; stalactites, stalagmites, etc.

Be aware of sensitive cave structures and features.

- **Goethite/ phreatite formations**
- **Sediment formations / Clay Banks**
- **Delicate formations**
- **Cave fauna and bacteria colonies**
- **Speleothems; stalactites, stalagmites**

LANDOWNER RELATIONS

Access to all cave diving sites is controlled by the landowners either private or governmental. Courtesy and respect are our best means to keep the access to these sites open. Without constant encouragement and cooperation, and our access privileges will be lost.

Land categories;

- Federal or State owned/controlled.
- Public/private parks.
- Private lands.
- Closed or special access sites.
- Simple trespass sites, which are un-posted locations, typically private land with a tradition of public access.

It is important to develop and maintain good landowner relations:

- Abide by, and respect rules at private resorts and public parks.
- Individual cave divers tend to represent the entire cave diving community in the diving and non-diving public's eye; act appropriately!
- Promote overhead environment safety to other divers on-site by explaining Accident Analysis and the No Lights Rule when appropriate and in a courteous manner.

NOTES

Goethite is a mineral deposit composed mainly of iron and manganese oxides that is believed to be formed with the aid of bacteria. These formations appear in many forms such as the black crust on cave walls, black/brown crust on clay or sand substrates or even hollow tree stump appearing formations.

CAVE FAUNA

- 1. Troglodytes:** Fully cave-adapted animals, dependent on the cave environment.
Examples: crayfish, amphipods, isopods, salamanders.
- 2. Troglophiles:** Animals that utilize cave habitats, but not exclusively.
Examples: catfish, American eel.
- 3. Troglonexes:** Occasional visitors into the cave environment.
Examples: open water fish species, humans.

- TAKE NOTHING BUT PICTURES!
- LEAVE NOTHING BUT BUBBLES!
- KILL NOTHING BUT TIME!

ACCIDENT ANALYSIS

The NSS-CDS estimates that over 570 divers have perished in underwater caves in North America since 1960. This represents an average of over 10 diver fatalities per year in this type of overhead environment. Although there are many more fatal diving accidents when considering all types, cave-related diving fatalities are almost always preventable. The careful examination of these past accidents has had an overwhelming effect upon training and behavior within the cave-diving community.

In 1977, an NSS-sponsored study of cave-related diving accidents, for which there was sufficient detail, revealed some very significant information. By compiling a list of safety procedures and checking off the ones violated in fatal accidents up through 1975, pioneer cave diving instructor Sheck Exley discovered that three primary safety violations accounted for all fatalities. In 1983, NSS-CDS Training Chairman Wes Skiles revised this list of safety violations to account for two additional contributory factors. The lists of these safety violations and contributing factors are presented as Accident Analysis.

For the General Diving Community:

1. Lack of **training** in cave or cavern diving. *(A major contributory factor.)*
2. Failure to run a continuous **guideline** to open water. *(The most common direct cause of cave and cavern diving fatalities.)*
3. Failure to reserve at least two-thirds of starting **air** supply for exit; also known as the Thirds Air Rule. *(The second most common direct cause of cave and cavern diving fatalities.)*
4. Exceeding the maximum **depth** limits for your level of training or the complications of depth (increased breathing gas usage); maximum depth limit for Cavern or Basic Cave is 100 feet / 30meters, and 130 feet / 40 meters for any other recreational cave diving activity. Also, exceeding the Maximum Operating Depth (MOD) of the gas used. *(The third most common direct cause of cave and cavern diving fatalities.)*
5. Failure to use at least three **lights**. *(A major contributory factor.)*

Training

The

Guideline

Good

Air

Alert

Depth

Diver

Lights

Lives

For the Cave Diving Community;

The following items are direct and contributory causes of fatalities among trained cavern and cave divers, and are also listed in order of frequency of occurrence.

1. Exceeding the **depth** limit for level of training or experience or the complications of depth (increased breathing gas usage). Approximately 80% of trained cave diver fatalities have occurred at depths greater than 150 feet / 45meters. The maximum safe depth for recreational diving use of compressed-air diving is 130 feet / 40 meters. Today, with the use of breathing gases other than air, one must consider the **Maximum Operating Depth** (MOD) of the gas they are using. Equivalent Nitrogen Depth (END) should not exceed 130 feet / 40 meters.
2. Failure to use a continuous **guideline** to open water. This also includes failing to properly mark, a n d gap or jump navigation points with line during the dive.
3. Failure to reserve at least two thirds of the beginning gas (**air**) supply to exit the cave.
4. Exceeding level of **experience and / or training** .

NOTES

Exceeding the limits of one's training, skill, and experience, and/or having attitudes of invincibility, carelessness or complacency are key contributing factors to any cave diver fatality.

Cave Divers must maintain navigational certainty (know your exact location within the cave and how to get out) as well as reserve an overall adequate gas supply during a dive.

PSYCHOLOGICAL ASPECTS & STRESS CONTROL

Motivations: There are many reasons people explore caverns and caves. One's motivations for the dive often sets the tone and pace of that dive. Accepting varied motivations can help prepare us to evaluate the dive as it unfolds, providing the motivations never lead us away from basic safety practices. Never assume your partner's motivations are the same as yours; be aware of their motivations and expectations and discuss when necessary.

- Positive Motivations
 1. Discovery and enjoyment of new and unique environment.
 2. Exploration of the unknown.
 3. Technical interests and development.
- Negative motivations
 1. Thrill seekers.
 2. "Red Flag " syndrome; some are drawn to the activity because of perceived risks or dangers.
 3. "Innocent and ignorant".
- Ego
 1. Positive; seeking constant improvement.
 2. Negative; "invincibility", "ego threat", "big-boy syndrome" (improper encouragement).

Stress: Pressure from within and without that can make one tense, anxious, and fearful. Typically, stress will occur in combination from a number of sources.

- Psychological stress sources:
 - Time pressure.
 - Directional requirements.
 - Ego threat.
 - Self-doubt.
- Physical stress sources:
 - Exertion and cold.
 - Equipment out of adjustment.
 - Buoyancy.
 - Water current.
 - Loss of visibility; disorientation.
 - Sufficient air.
 - Physical injury underwater.
- Task Loading:
 - An accumulation or layering of psychological and physical stresses.

The Panic Cycle:

- Initial stages; mentally masking or ignoring stress.
- *Fight or Flight Syndrome*; A feeling of terror begins to take control.
- Panic; Ultimate failure to cope with stress. Can result in a fatality and has no place in cave diving. The diver must prevent the Panic Cycle from ever taking hold of them.

Recognizing stress:

- In yourself:
 - Uncomfortable mentally or physically.
 - Fatigue.
 - Loss of concentration.
 - Frustration.
 - Obsessive behavior.
- In others:
 - Narrowing of perception, fixation.
 - Not answering signals.
 - Clumsy and uncoordinated behavior.
 - Technique deteriorates.
 - Frustration.
 - Wide-eyed look, dilated pupils.
 - Muscle tension and stiffening, freezing up.
- Reacting to stress:
 1. Stop activity.
 2. Make sure gas supply is secure.
 3. Deep breathing until calm.
 4. Identify source of stress or problem.
 5. Solve problem; continue or call dive as needed.
- Predicting, avoiding, and coping with stress:
 1. Identify and eliminate all possible sources of stress as is practical.
 2. Reduce all possible sources of stress that cannot be eliminated.
 3. Learn to cope with all sources of stress that are not eliminated or reduced.
 4. Accept that a certain level will exist; anticipate it.
 5. In the right quantities stress is good for us.
 6. Practice all skills, especially emergency skills that would be used under stress.
 7. Pre-visualize the dive.
 8. Put safety before fun.
 9. Remember the Golden Rule.

NOTES**Motivations**

Positive Motivations

Negative motivations

Ego

Commitments

Physical

Mental

Time

Monetary

Stress

Psychological

Physical

Task Loading

PSYCHOLOGICAL ASPECTS & STRESS CONTROL (CONTINUED)**Reducing Stress:**

- **Proper Attitude:**
 1. Respect the limits.
 2. Use common sense.
 3. Exercise mature judgment.

- **Ability**
 1. Mastering skills; practice and repetition.
 2. Additional training.
 3. Feedback , critique among dive partners.
 4. Observing and imitating individuals with developed skills.

- **Awareness**
 1. The mental ability to take in and process necessary and changing information (environment, team, equipment, self, etc.) during a dive; a “conscious knowing”.
 2. Increases with experience and repetition.
 3. Increasing awareness expands a diver’s “circle of knowledge” and “comfort / safe zone” with every dive.

- **Perception of risk**
 1. A combination of Attitude, Ability and Awareness that helps divers stay within their comfort/safe zone.
 2. Anticipating and avoiding potential problems.
 3. Cave diving is a controlled risk activity; as it is impossible to eliminate all risk, it must be minimized at every opportunity.

An awareness of the limits for Cavern, Basic Cave and open water divers is very important for cave divers. Cave divers must stay within these limits when diving with non-cave divers.

Open water divers can dive relatively safely if:

1. They avoid entering caverns and caves completely, remaining in the direct ascent zone.
2. They do not take lights along on the dive; the No Lights Rule.
(The No Lights Rule is enforced at many dive sites.)

Limitations for trained Cavern Divers are recognized as:

- The daylight zone of the cavern, and always within sight of the surface entrance.
- Penetration limited to 1/3 of single cylinder or 1/6 of twin diving cylinders.
- Minimum 72 cu. ft. / 2039 liters volume tank with starting pressure of 2000 psi/ 140 bar at start of dive.
- 200 feet / 60 meters maximum distance from the surface.
- 100 feet / 30 meters maximum depth.
- 30 feet / 10 meters minimum starting visibility.
- Penetration in the daylight zone only (on a primary reel), no traverses, dives start and end at same point, no complex navigation.
- No decompression stops (safety stop as needed/prudent).
- No restrictions (areas too small for two divers to pass through together).
- No original exploration.
- No goal oriented dives.
- No solo diving.

Limitations for trained Basic Cave Divers/Intro Cave Divers are recognized as:

- Penetration limited to 1/3 of single cylinder or 1/6 of twin diving cylinders.
- Minimum 72 cu. ft. / 2039 liters volume single tank with starting pressure of 2000 psi./ 140 bar at start of dive for Intro Cave and if in twin cylinders, minimum 72 cu ft/ 2039 liters volume for each tank with starting pressure of 1800 psi./ 124 bar.
- 100 feet / 30 meters maximum depth.
- 30 feet / 9 meters minimum starting visibility.
- Main line penetration only, no jumps or gaps, no traverses, dives start and end at same point, no complex navigation.
- No decompression stops (safety stop as needed/prudent).
- No major restrictions (no gear removal).
- No original exploration.
- No goal oriented dives.
- No diver propulsion vehicles in cave.
- No solo diving.

UNDERWATER CAVE FORMATION & TERMINOLOGY

Note: Geology is a specialized discipline beyond the scope of this course, but the basic information presented here can provide insight into what you will observe as a cave diver. The NSS headquarters in Huntsville, Alabama can be contacted for more extensive information regarding caves and karst hydrogeology.

Types of caves

- Coral caves (Figure 1, facing page.)
 - Typically in living coral heads.
 - Small in size.
- Sea caves (Figure 2, facing page.)
 - Formed by wave action along rocky shoreline or coast.
 - Especially affected by tides.
- Lava tubes (Figure 3, facing page.)
 - Created and formed by volcanic action.
 - Water then may act as a secondary force creating changes and conditions.
- Dissolution Caves (Figure 4, below.)
 - Longest and most complex.
 - Caused by dissolution of carbonate sedimentary rocks.
 - Common throughout the world in karst terrains.
 - Most familiar to cave divers.

Dissolution cave formation and structure:

- Layers of soluble sedimentary rock (bedding planes).
 - ⇒ Typically carbonate rocks; limestone (CaCO_3) and dolomite (MgCO_3).
- Aggressive (CO_2 rich) water often dissolves limestone.
 - ⇒ Follows path of least resistance and gravity.
 - ⇒ Other sources of acidity.
- Sources of water and artesian pressure:
 - Drainage/recharge area.
 - Size and depth of aquifer.
 - Hydrostatic head.
 - Confining layers.
- Karst - an internationally used term that describes a terrain, generally underlain by limestone, in which the topography is formed by the dissolving of rock, and is characterized by closed depressions (sinkholes, or dolines), underground drainage, caves, and other features.

- Vadose Cave Formation, Vadose refers to cave passageways or other spaces formed above the normal water table of the area. The enlargement process is enhanced by flowing streams and solution, and is affected by gravity and the cave atmosphere. This often results in decorations collectively called speleothems.
- Phreatic Cave Formation, Phreatic refers to submerged cave passageways or other spaces formed and enlarged below the normal water table (or level) of the area. This implies enlargement not only by chemical dissolution but also normal water flow over the rock formation. This process is also increased by the resultant rise in water pressure as great flow is directed through a limited-size passageway.
- Vertically oriented passageways:
 - Fissures
 - Fractures
 - Joints
- Horizontal oriented passageways:
 - Bedding planes
 - Phreatic tunnels
 - Key holes
- Rooms and chambers
- Breakdown
- Cave entrances; springs and karst windows.

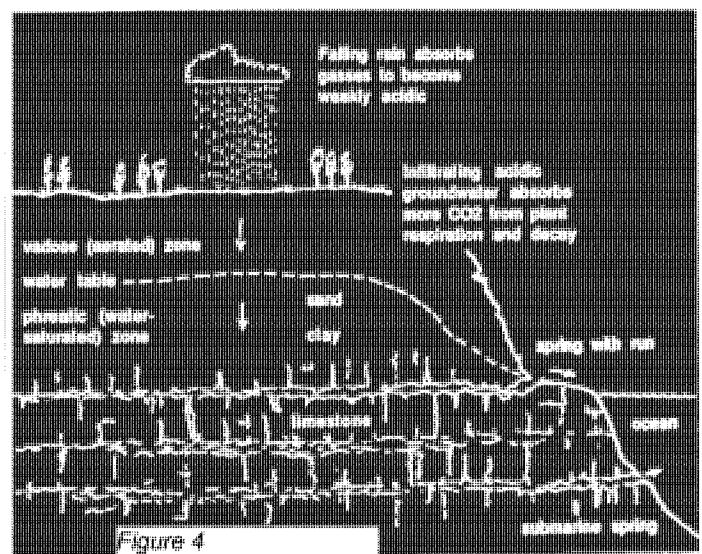

UNDERWATER CAVE FORMATION & TERMINOLOGY

Coral cave with 5 different entrances



Figure 1.

Types of caves

- Coral caves*
- Sea caves*
- Lava tubes*
- Dissolution caves*

Sea Cave

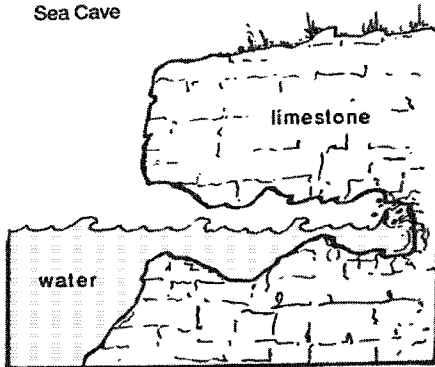

Figure 2.

Vertically oriented passageways:

- Fissures*
- Fractures*
- Joints*

Lave-tube Cave

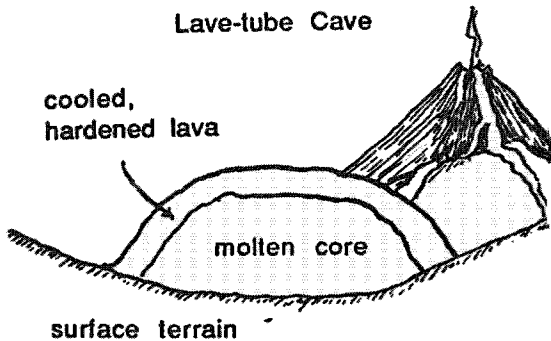

Figure 3.

Horizontal oriented passageways:

- Bedding Planes*
- Phreatic Tunnels*
- Key Holes*

TYPES OF UNDERWATER CAVE ENTRANCES

Springs:

These are cave openings through which water emerges under normal conditions. These may be the historical exit of water from the cave, generally found near the bottom of the cave, or may be a higher opening which now serves as the hydraulic exit due to a rising water table.

- Vent or orifice that discharges water.
- Head pool and run, connected to another surface water body at a lower elevation.

Identifying characteristics;

- Pool will usually have a boil on surface.
- Lighter debris and particles are pushed away.
- Referenced as an upstream flow.

Siphons (or Syphons):

These are cave openings into which water flows under normal conditions. In some coastal areas the same openings may be considered a spring or a siphon as water flows in and out with the tide. Other openings along river courses which are normally springs may also become siphons when the river rises and reverses the normal hydraulic pressures.

- Underground opening into which surface water flows.
May also be called sinks, swallets or estavelles.

Identifying characteristics;

- Circular or patterned water movement (absence of boil) on surface..
- Local accumulation of debris.
- Observing actual movement of water and particles into opening.
- Referenced as a downstream flow.
- Provide additional dangers; refer to *Specific Hazards section*.

Spring-siphon complexes, or “karst windows”:

This is another common configuration encountered by cave divers. In this configuration water enters the bottom of a sink via a spring tunnel, crosses the sink chamber, and exists via a siphon tunnel. The flow can be quite substantial and may or may not be obvious in the surface basin above the sink opening.

Typically found as part of conduit cave systems.

- May form discreet openings above conduit due to collapse or solution and function as key openings into a cave system;
 - Flowing sinks
 - Offset sinks
 - Chimney or solution shaft entrances

- Rise and sink streams, rivers or sloughs (insurgence/resurgence).
- River cave systems.
- All of the above can be affected by seasonal flooding cycles.

Sinkhole systems:

- Often have hourglass-shaped profile.
- Debris cone in center of bottom often a prominent feature.
- Typically exceed 130 feet / 40 meters in depth.
- Often located away from river basins.

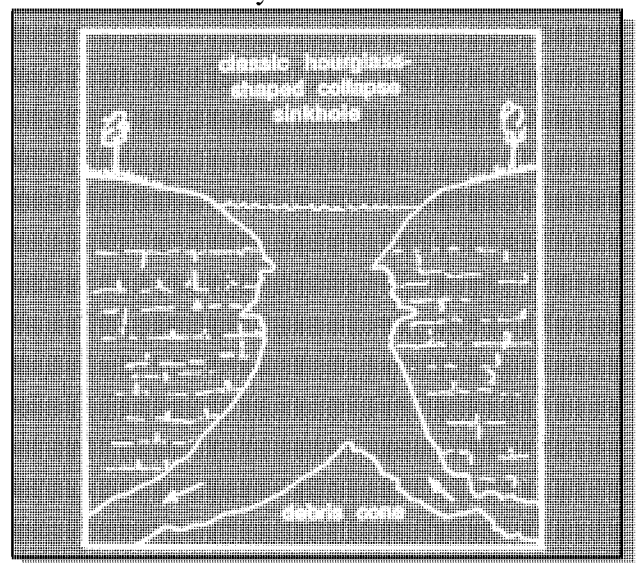

Cenotes:

- Spanish for “well;” usually referring to sink holes or conduit-connected karst windows, typically in Mexico’s Yucatan Peninsula karst.
- Caletta; Local name (Yucatan peninsula) for inletted coastal spring.

Other submerged cave terminology:

Caution: *The entering of, or exploration in these areas is beyond the scope of this level of training.*

- Blue holes - In or near ocean sink or cave system and is affected by daily tidal flows.
- Sump - A water-filled section of a cave that terminates an otherwise air-filled passage; often called siphons by dry cavers.
- Underground Lake - Air-filled cave rooms, or sections of a very wide passageway partially filled with water; these areas resemble a lake and therefore are given this name.

TYPES OF UNDERWATER CAVE ENTRANCES (continued)

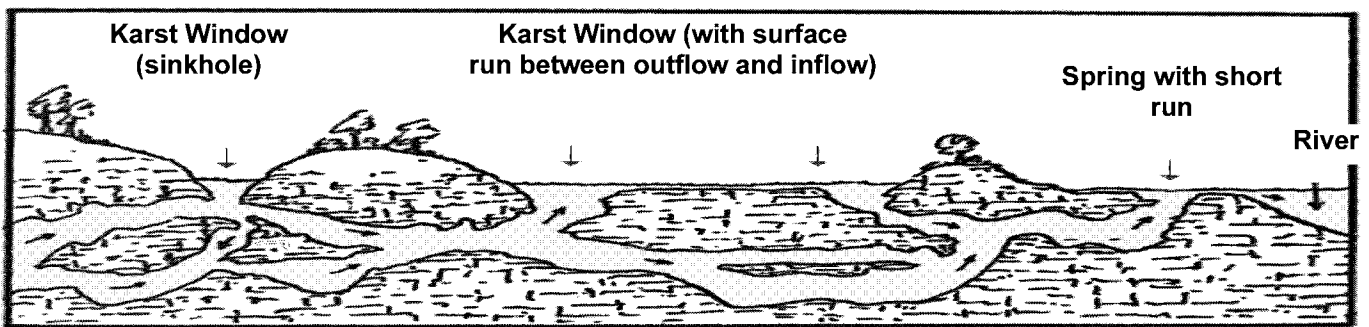

NOTE: The direction of flowing water can change within a cave system. This can also occur when the depth of an adjacent river increases due to flooding, causing a reversal of flow in the system. Caves that flow into the ocean will have a change in the flow due to tidal rise and fall. Cave divers must always be aware of flow characteristics and possible changes - especially those that may occur during the duration of a dive.

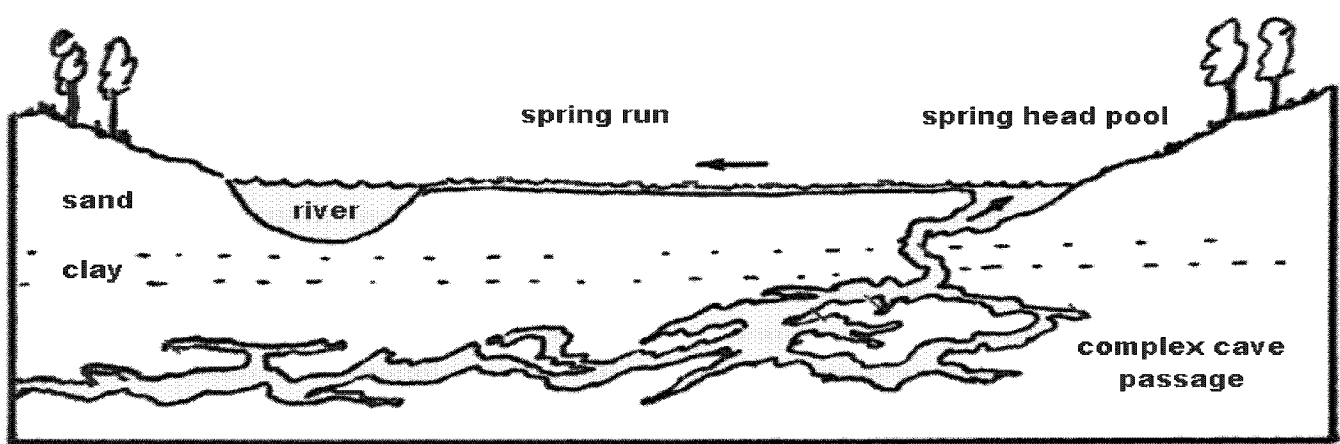

GENERAL HAZARDS of the CAVERN/CAVE ENVIRONMENT

- Water.
- Ceiling; no direct exit to surface.
- Limited space.
- Darkness; loss of directional reference.
- Distance.

Know your limitations and the limitations of your team members; always dive well within those limitations!

Combination of all of the above;

Increased stress loading, and is most typical.

The characteristics listed above typically produce, or are the direct cause of stress. In cavern and cave diving environments, all of those characteristics/hazards are present by definition and tend to increase the stress levels (task-loading) of those who enter overhead environments. With proper training, equipment configuration, experience and remaining within your limitations of training, the cavern/cave diver can reduce the level of task-loading.

SPECIFIC HAZARDS of the CAVERN/CAVE ENVIRONMENT

Visibility

- Sediments; classified by particle size and composition:
 1. Sand.
 2. Silts:
 - a. Mud silt.
 - b. Clay silt (smallest particles).
 3. Decomposing organic materials; leaves, peat, etc.
 4. Bacterial growth and residues; esp. in marine caves.
- Sediment Agitation - Silt is not, in itself, a problem until it becomes agitated.
 1. Poor swim and trim technique.
 2. Diver's equipment dragged across the bottom.
 3. Percolation caused by the diver's exhaust bubbles hitting the ceiling can result in silt being dislodged from the ceiling.
 4. Silt may stick to diver and equipment, especially clay silts.

- Chemicals
 1. Tannic acid.
 2. Hydrogen sulfide.
 3. Haloclines- different layers of water with various degrees of salinity and density. The mixing that results as the diver passes through the layers will distort vision.

Flow

- Higher flows.
 1. Resistance while entering cave, "assistance" on exit.
 2. Narrowing of passage can mean increase in flow.
 3. Usually means less sediment in main passages, but disturbed sediments can travel with diver to exit.
 4. Need to anticipate buoyancy changes.
- Low or no flow
 1. Return swim may require as much or more air, time and effort as did the swim to turn point.
 2. Passages may be more silty in general, with percolation more common.

NOTES

Disturbed

Most Easily.....Least Easily

Mud

Sand

Clay

In Suspension

Longest Shortest

Clay

Mud

Sand

SPECIFIC HAZARDS

(continued)

Flow (Continued)

- Downstream or siphon flow;
VERY dangerous to cavern/intro/basic divers.
 1. Specific dangers to dive team;
 - Increased exertion and air consumption on exit.
 - Normal thirds rule doesn't work.
 - Debris and silt travel in with dive team.

Restrictions

- Force dive team into single-file travel.
- Line of sight through restrictions may not be best travel path.
- May be silty.
- Create exit delays.
- *Not allowed at the Cavern level of training.*

Passage configurations

- Important when referencing; pay attention to cave features such as breakdown, bedding planes, vertical structure, etc.
- Mazes.
- Branching conduits.
- Always make sure passage is large enough for team to turn the dive effectively and safely.

Line Traps

- Guideline running through an area through which divers cannot pass, or would have extreme difficulty negotiating, if forced to follow the line in limited or zero visibility conditions.
- Change of passage direction.
- Switching sides in passage.
- Restrictions.
- Bedding planes.

Air Pockets (on ceilings)

- Formed by trapped exhaust air, organic gases, or in some cave passages where the cave is located above the water table.
- May contain high levels of gas (carbon dioxide, methane, etc.) as well as low oxygen levels.
- When ascending into air pockets, extreme care should be taken to avoid damage to your equipment and the cave environment.

NON-ENVIRONMENTAL HAZARDS

Equipment Failure

- **Loss of light:**
 - Loss of primary light source may slow your exit, requiring more time and gas.
 - Causes:**
 1. Failure to ensure back-up lights are in working order.
 2. Failure to determine sufficient burn time.
 - Result:** Touch-contact may be required for safe exit.
- **Loss of gas supply:**
 - Causes:**
 1. Failure to correctly calculate and monitor gas supply.
 2. Gas escaping due to failure of O-rings, equipment impact with ceiling, etc.
 3. Failure to isolate escaping gas.
 - Result:** Gas sharing may be required for safe exit.
- **Loss of continuous guideline to the exit.**
 - Causes:**
 1. Most common is failure to run or maintain continuous guideline.
 2. Guideline is disturbed/broken by others.
 - Result:** Lost line procedures must be utilized to relocate line for safe exit.

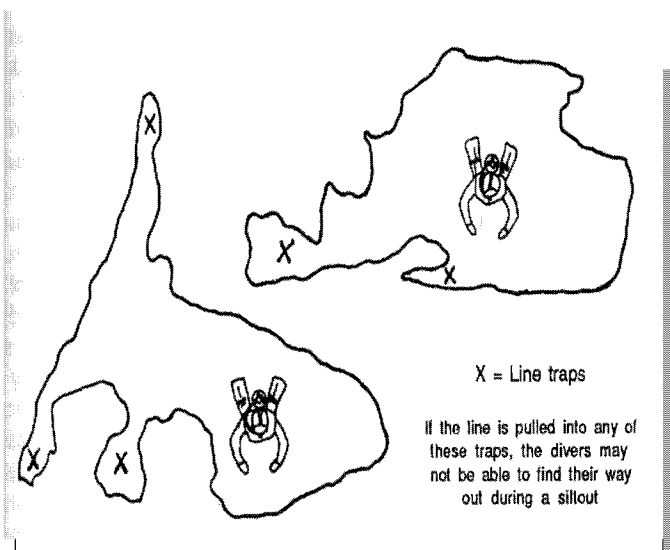

NOTES**GENERAL HAZARDS**

- *WATER.*
- *CEILING.*
- *LIMITED SPACE.*
- *DARKNESS.*
- *DISTANCE.*

SPECIFIC HAZARDS

- *VISIBILITY.*
- *CURRENT.*
- *RESTRICTIONS.*
- *PASSAGE CONFIGURATIONS.*
- *LINE TRAPS.*
- *AIR POCKETS.*

**NON-ENVIRONMENTAL
HAZARDS**

- *LOSS OF LIGHT.*
- *LOSS OF GAS SUPPLY.*
- *LOSS OF GUIDELINE.*
- *OTHER EQUIPMENT FAILURE.*

EQUIPMENT

Vision

- Mask
 - Remove snorkel..
 - Carry a spare mask (recommended).

Lights

- Primary light
 - Use appropriately powerful light; typically a halogen- or HID-type rechargeable light system.
 - Should have a burn time equal to or greater than the total planned dive time.
- Back-up lights
 - At least two must be carried.
 - Should have a collective burn time of at least twice the total planned dive time.
 - At least one should have fresh non-rechargeable batteries.
 (Lighting system specifics should be discussed in detail with the Instructor.)

Propulsion

- Power fins, with straps taped or reversed to prevent snags with the guideline.
- Straps replaced with spring type straps.

Air supply control

- Individual (self) back-up
 - Dual outlet valve.
 - Back-up regulator complete first and second stage).
- Team/buddy assistance
 - Seven-foot hose for air sharing.
 - Reliable and effective alternate second stage with retainer.
 - Long hose/short hose management.

Buoyancy control and trim

- Buoyancy compensator / harness / power inflator system
 - Back-mounted (wings) w/harness and plate.
 - “Technical” style harness and BCD.
 - Open shoulder or jacket.
 - Crotch straps.

Weights

- Minimize amount.
- Redistribute on body and equipment.
 - Use of a drop weight.
 - Benefits of aluminum vrs steel back plate

Exposure protection

- Thermal protection should be suitable for local diving conditions (discuss with instructor).
- Dry suits -neoprene or tri-lam shells.
- A 6.5 to 7 mm, one or two piece wet suit and hood is usually sufficient for this level of training. (Florida-Caribbean area.).
- Addition of a hooded vest may increase thermal comfort level.
- Gloves, if worn, should be fingerless unless colder temperatures demands more.

Instrumentation

- Dive computer (nitrox compatible or multi gas models are recommended).
- Timing device and depth gauge.
- Submersible dive tables.
- Slate and pencil.

Guideline Reels and Accessories

- Primary reel
 - 350 to 400-foot (110 to 125 meters) line capacity.
- Safety reel
 - 100 to 150-foot (30 to 45 meters) capacity.
 - Sometimes called a Cavern Reel.
- Gap/jump reel or spool
 - 50 to 150-foot (15 to 45 meters) capacity (not necessary equipment at the Cavern or Basic Cave training level).
- Guideline type:
 - Diamond braid nylon line (twine).
 - # 24 size typically used on reels, but # 36 and # 42 sizes also popular.
- Line arrows and clothespins.

Knife

- “Z” style knife is safest.
- Needs to be compact and sharp.
- Must be easily accessible.
 - Best if not mounted on leg, but at waist level or higher.

Clips and Snaps

- Gated clips/snaps
 - Dog / bolt clips.
 - Butterfly clips.
 - Double-ended dog clips.
 - Trigger clips/snaps.
- Boat / Marine snaps/clips
 - This type is most prone to undo itself from Ring (catches line, other snaps easily).

NOTES

Clips and Snaps (continued)

- Attachment of snaps/clips to equipment.
 - Nylon Cord.
 - Split rings.
 - Metal links.
- D-rings and round rings.
 - *Always attach the snap/clip to the ring, never the opposite.*
 - Locate on harness or BCD; position with slides or sewn in place.
 - Attachment to cylinders with hose clamp.

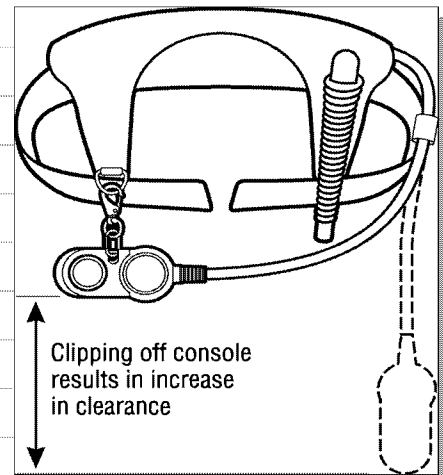
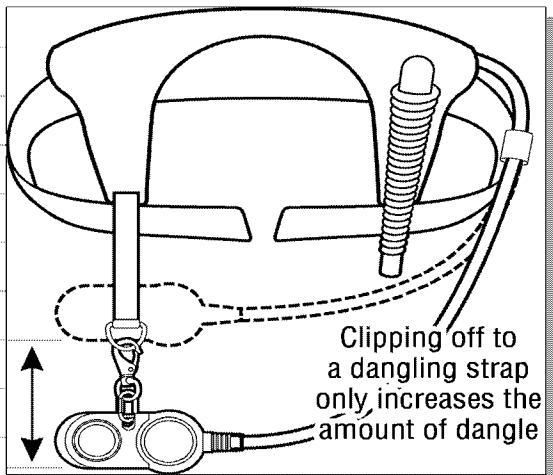
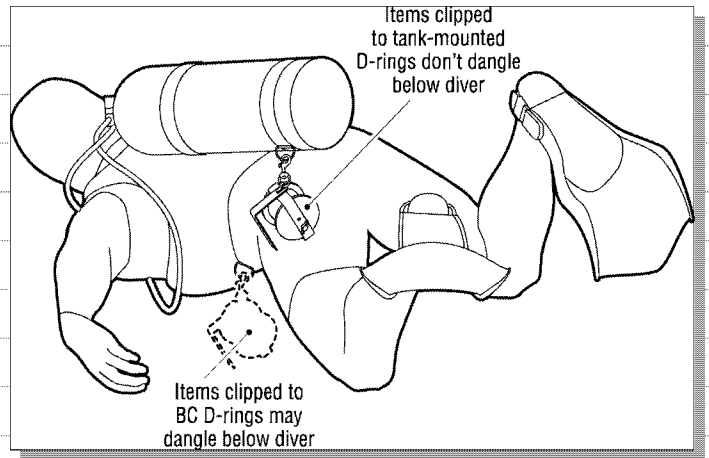
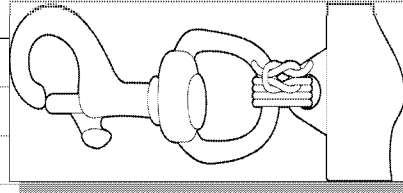

TRIM & PROPULSION

Trim control

- Factors involving trim
 - Positioning of weights.
 - Adjustment of BCD and cylinder.
 - BCD types:
 - 1) Back mounted "Wings."
 - 2) Open-shoulder jackets.
 - Cylinder types:
 - 1) Steel.
 - 2) Aluminum.
- Poor trim will cause:
 - Drag.
 - Un-wanted contact with line.
 - Silting caused by fin down-blast or contact with floor.
 - Damage to the cave.
- Buoyancy: requires continuous adjustments.
 - exposure suit - expansion and compression.
 - Affected by haloclines.
 - Affected by high flow.
 - Minimize amount of weight worn.
 - Use a drop weight, if necessary.

Propulsion

- Purpose and goals;
 - To minimize silting, percolation and impact on cave.
 - To maximize speed and efficiency.
 - Prevent diver overexertion and exhaustion.
- Swimming kicks
 - Modified Frog kick.
 - Modified flutter kick.
 - Shuffle kick.
- Contact methods; usually only used in high flowing water (such as North Florida caves).
 - Pulling (using hands); can cause damage/breakage to cave walls and floors.
 - Ceiling Push (using heel or fin-tip); can easily damage cave ceilings, and is not recommended.

Note: The use of contact methods is discouraged for any environment, and should only be used when absolutely necessary and when they will not cause cave damage.

GUIDELINES

General terms

- Tie-off or wrap;
 - A physical wrapping of line around an object to prevent line movement.
- Placement;
 - Positioning of line around an object to control line yet allow for easy removal.
- Line trap;
 - Areas that line may drift or be pulled into, but through which a diver is unable to pass.
- Tension;
 - The force needed to keep a line taut and under control, yet not stressed.

General types of guidelines and line markers

Novice Lines

- Usually a permanent line or rope installed in more popular cavern-diving locales to help guide untrained cavern divers to safely exit the cavern.
 - These lines are typically oversized in diameter, when compared to typical cave diving guidelines.
 - Permits the uninformed diver to pull and tug on the guideline without damage to same.

Temporary Lines

- Guideline laid by diver that is intended to be retrieved at the completion of the dive. Examples include the guideline carried on a:

Primary Reel; Used to form a continuous guideline between cave entrance and the permanent guideline within the cave.

Safety Reel; Used to locate a permanent line should diver become separated from same, or to search for lost buddy.

Jump/Gap Reel or Spool; Used by the cave diver to temporarily connect permanent guidelines. Also used by cave divers when exploring away from the permanent guide line.

NOTES

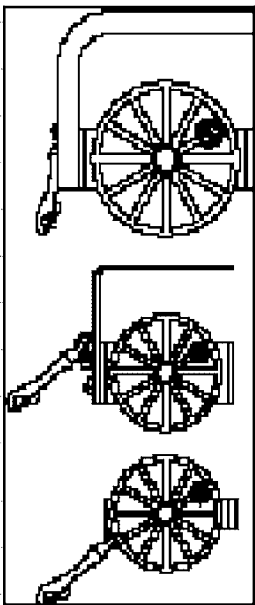
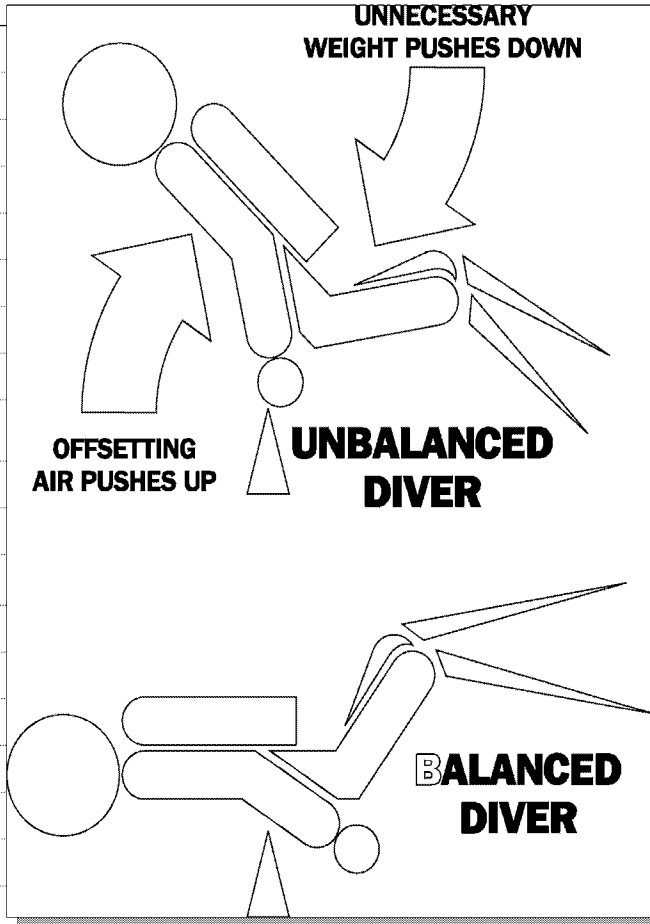

Cave Conservation Notes:

Systems with fragile formations of speleothems, such as those typically found in Mexico, Bahamas and Brazil can be devastated by the use of contact propulsion methods. In Florida caves, delicate formations sculpted by solution, structures formed by goethite/phreatite and layered banks of clay are also vulnerable.

Care and conservation should always be of the utmost concern of those who dive within them.

What developed over thousands of years, can be destroyed in a moment of carelessness.

GUIDELINES (continued)

Line Laying Terminology and Application

- Primary (initial) tie-off.
Made in the direct ascent zone to the surface. Should be placed low and as close to cave entrance as possible.
- Secondary tie-off.
Made just inside the overhead, to ensure a safe exit in the event the primary tie-off comes undone.
- Placements.
Made also to ensure line tension, however the line is not wrapped around an object, but simply placed or 'hooked' behind the object. Make placements with care so as to minimize impact to the cave.
- Wraps (additional tie-offs).
Made to ensure line tension, and should be used at a minimum. These can delay exiting in the event touch contact with the line is required. Avoid fragile structures and formations when making wraps/tie-offs.

DIVE TEAM PROTOCOLS

General Teamwork and Line Handling

- **Team leader's...**
Team responsibilities:
 - Primary duty: ensure that no team member penetrates further into the cave or cavern than the leader does and that all team members leave ahead of the leader when exiting.
 - Maintain team member contact and communication when turning corners.Line handling duties:
 - Maintain appropriate line tension at all times; keeping the reel hand/arm extended will help.
 - Avoid entanglements.
 - Keep reel in the hand of the direction you are turning to avoid contact with body and equipment.
- **Second team member's...**
Team responsibilities:
 - Provide light as needed.
 - Be ready to provide general assistance.
 - Relay communications to/from leader

and rear; maintain overall team contact.

Line handling duties:

- Recheck line placement when entering.
- Assist with the maintaining of line tension whenever reel is in play.
- Assist with line recovery as needed and as appropriate on exit.

- **Third team member's...**

Team responsibilities:

- Provide light as needed.
- Be ready to provide general assistance.
- Lead out during exit.

Line handling duties:

- Recheck line placement when entering.
- Stay out of way as is appropriate; let team leader and second diver handle line, especially on exit. Provide assistance with line handling only when it is truly needed (examples: entanglement, snags, etc.).

Dive Team Protocols: Line Following and General Considerations

- Stay only close enough to the line to keep a visual reference.
 - there is no need to touch the line when visibility is good.
- Develop "Line Awareness".
 - its location and exit direction, and your position relative to it.
- Always be conscious of the line.
 - it should be within easy and known reach if vision is quickly lost.
- Do not switch positions within the team.
 - **The first diver in should be the last diver out.** Positions may be switched as required when dealing with a team emergency or problem.
- You should always cross over a guideline and never under it.
 - If it's absolutely necessary to go under a line, hold line in extended hand as you pass under.
- Do not pull or tug on the line.
 - a line is meant to be used as a directional reference, not a means of propulsion.

NOTES

Wraps are used more commonly in the running of permanent lines or survey lines.

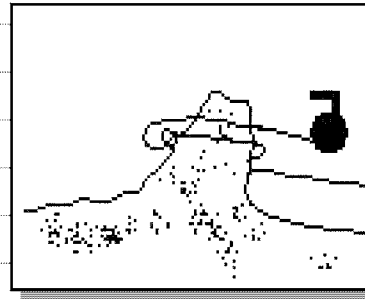

Placements are the preferred method of ensuring tension on the line, especially when running temporary lines.

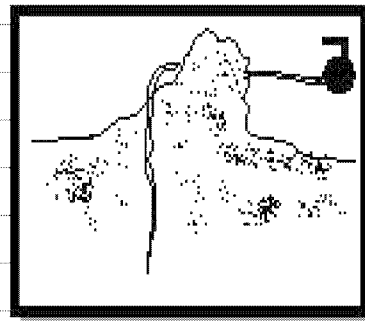

GUIDELINES (continued)

Dive Team Protocols: Jammed Reels

No matter how carefully one tries to operate a reel, line jams and backlash may occur, usually during exiting. These and other causes may render the reel inoperable, but the reel can still be used to collect and manage the guideline.

- Make a reasonable attempt to un-jam the reel, if time and environment allow for it.
- Secure reel with lock screw and use free hand to wrap line around outside of stationary spool.
- In an emergency or if compounding problems, secure reel and tie off, then exit cave.

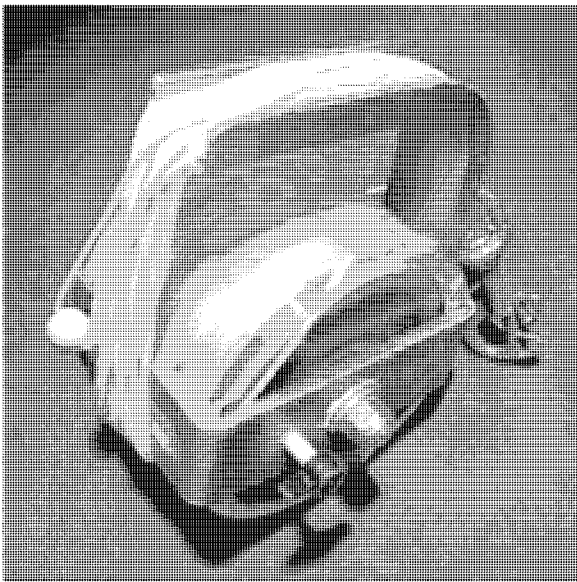

Cave Diver Traffic: Protocols and Etiquette

- Do not disturb other's lines and equipment in the cavern or cave.
 - This includes items such as safety/deco cylinders, drop weights, pouches, DPV's, etc.
 - Lay your line to so as to avoid interference with other lines and equipment in the cave or cavern.
 - It is possible and likely that more than one team will be exploring the same cave system at the same time.
- *Refer to 'Cave Diver Traffic: Guideline Techniques' below for best actions to take.
- Generally, exiting teams have right-of-way over teams entering the cave.
 - Exceptions; exiting team encountering students or another team having difficulty

entering the system, should yield, if in doing so poses no problems or complications. For example, in the presence of restrictions or high flow.

Never use another team's line without their permission;

- A plan of action is also required to assure that no one is left behind in the cave without a line.
- It is best to completely avoid reel and line sharing practices until more training and experience is acquired.

Cave Diver Traffic: Cooperative Guideline Techniques

As it is necessary for one team to take appropriate action to avoid another team's temporary guideline, consider the following actions;

- Be courteous to other teams.
- Of primary importance is to place your line so that the other teams may exit without becoming delayed, snagged or entangled in your guideline.
 - This means that your line will probably be run under other lines.
- Avoid tie-off and placement locations that are already being occupied with another team's line.
- Also, avoid crossing your line over other lines in the cave or cavern.
 - This may mean that you have to use a less desirable tie-off or have to exit and wait for other teams to exit. Again, it also means running your line under other lines.
- Avoid using high tie-offs or placements.
- Avoid running your line across the cave or cavern entrance or cave passage.
 - By doing so, you will provide other teams entering behind you with more options for running their lines.
- Avoid 'zig-zag' line lays and tie-offs.
 - Keep to one side of passage as much as possible.

NOTES

Cave Diver Traffic: Four Main Rules of Protocol and Etiquette

Purpose: To establish and maintain cooperative principles for numerous teams to follow while running guidelines within cave systems.

- **Do not disturb other guidelines or any equipment placed within the cave.**
- **Lay your team's line so that it does not interfere with other lines or equipment in the cave or cavern.**
- **Give right-of-way to exiting teams** (see exceptions on the previous page).
- **Never use another team's line without their permission.**

COMMUNICATIONS

Light Signals

Permit you to communicate general ideas easily and at a distance.

- O.K. = Circular motion.
- ATTENTION = Slower **narrow** back and forth motion, typically in **short pulses**.
- EMERGENCY = Wide up and down, or side to side **rapid motion**, typically constant until there is a response.

Hand Signals

Permits you to communicate more detailed information quickly.

Command Signals

These signals always demand a response or confirmation.

- **“CALL/TURN DIVE”**; Dive is over, surface.
 1. Entire team exits toward original entry point.
 2. Anything that resembles “surface” signal means surface, not left, right, or down.
- **“OK”**; “Are you OK?” (or, “Yes, I am OK.”)
 1. Anything else may indicate trouble.
 2. May be given as an answer to a question. Usually no confusion about its use as a command signal, since it is given as a response to a query.
- **“HOLD”**; maintain position at a given location.
 1. Come to a complete hold or stop.
 2. Signal to continue is “OK”, given by person originally signing “Hold”.

Line Signals

“LINE”; usually followed by:
 “TIE-OFF”
 “REEL”
 “TANGLE”
 “CUT”

Other hand signals pertinent to cavern/cave diving

“SILT”
 “DIRECTION”
 “BUBBLES” (LEAK)
 “LIGHT IS ON”
 “QUESTION”
 “SLOW DOWN”
 “OUT OF AIR”

“PROBLEM/BAD”

“TURN AROUND/CHANGE DIRECTION”

“DECOMPRESSION(?)”

“NUMBERS”

NOTE!

When using hand signals it is necessary to illuminate your hand so other divers can see the signal. It is important not to shine your light into the eyes of the other divers, this could result in loss of vision and cause divers to lose sight of the line.

Touch-Contact

By using tactile methods divers can communicate where low or no visibility, or an emergency, prevents the divers from using direct visual communication.

Can be used on or off guideline.

- “FORWARD”; push forward.
- “BACK-UP”; pull backward.
- “STOP”; one or two firm squeezes.
- “CROSS-OVER LINE”; lead diver reaches back, places buddies free hand on line.
- “ENTANGLED”; use “line” signal.
- “EMERGENCY”; shake arm or leg.

Slate

This piece of equipment allows for more complex communications and dive data logging. A slate may be worn on the divers arm or carried in a pocket. Extreme care should be taken when using a slate to communicate to other divers. This method requires the team to become closely grouped to see the written message and possibly cause the following to occur:

- Silting due to poor trim.
- Loss of line due to distraction
- Loss of reference to the exit.
- Entanglement with the line.

NOTE!

The dive team should review communication signals to ensure everyone understands the signals that will be used by the team. This practice is part of the pre-dive planning.

NOTES

***OKAY**

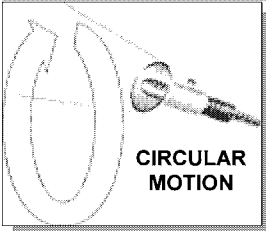

***ATTENTION**

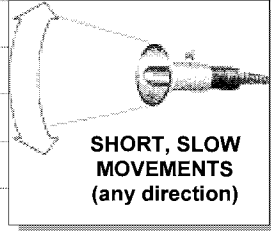

***EMERGENCY**

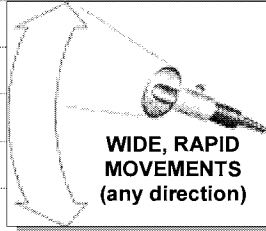

*** COMMAND SIGNAL – Requires response or confirmation**

OK

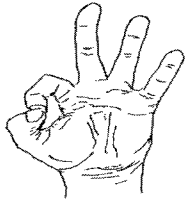

Call/Turn Dive

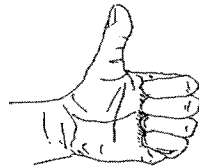

Hold



Line

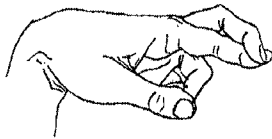

Slow Down

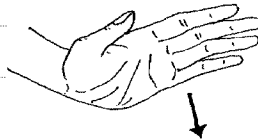

Entangled



Tie Off

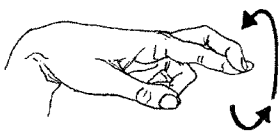

Silt

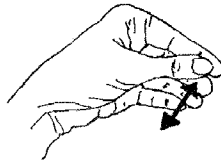

Bubbles



Question



Light On

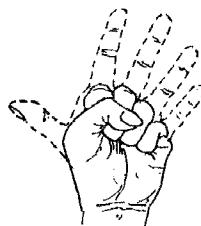

See: *Cave Diving Communications* by Prosser and Grey

DIVE PLANNING & PROCEDURES

Pre-dive Planning

- Self-evaluation; are your skills and equipment suitable for the location and the difficulty level of the dive?
- Dive team member evaluation; answer same questions as for self-evaluation.
- Make a dive plan, but avoid goal-oriented dives.
- Establish dive (team) limits.
- Equipment considerations.
- Dives must be planned using tables / software to determine gas volume requirements.

Dive Site Inspection

- Water condition.
- Water entrance.
- Cave entrance location.

Team Organization

- Select a team leader.
- Positioning of team members.
- Review signals.
- Review team dive objectives. Make sure all agree.
- Always remember the Golden Rule for turning a dive:

**ANYONE CAN CALL ANY DIVE
AT ANY TIME FOR ANY REASON.**

Equipment Check: (prior to suiting up)

- Determine equipment needed for the dive.
- Inspection of all personal & team equipment.
- Record dive plan limits.

In-Water Pre-Dive Check:

Performed by all team members.

1. "Head-to-toe" equipment check. (match method)

Note: If surface conditions do not allow for in water check then this step can be performed before entering the water.

- Check **ALL** lights underwater for function and leaks.
- Check reels, number needed and accessibility.
- Check instruments, knife, watch, tables, slate and pencil, etc.

2. "Bubble" (leak) check of submerged equipment.

- Test **ALL** regulators while breathing underwater and examine valves for leaks.
- Test BCD and dry suit power inflators.

3. Safety or "S" Drill.

- In shallow water, the agreed upon diver gives the out-of-air signal.
- The donor assists in giving the alternate air source as appropriate for the equipment configuration. (see NSS/CDS recommended gear configuration)
- While stationary, the team is to establish touch-contact position.
- When ready, divers are to swim a short distance while remaining in touch-contact.
- The drill is to be repeated prior to every dive by all members of the team.

4. Establish gas turn-around and review dive plan.

- Establish dive plan and turn-around pressure/time.
- Check computer and tables for no-decompression limits.

Planning Air Supply Limits

- Starting air supply;
 - Always begin the dive with at least the minimum volume appropriate for the level of training, and reserve at least two-thirds of your starting volume for exiting. The principle to be applied is that the team must match penetration gas. This means that the diver in the team with the lowest volume will set the penetration volume for each member of the team.
- Always use the standard method for calculation of thirds.
 - 1) Round down from total starting psi to number evenly divisible by three.
 - 2) Divide by three.
 - 3) Subtract this third from total starting psi (not the number you rounded down to!)
 - 4) **Note** starting pressure and calculated turn-around pressure..

Example: Starting pressure is 2950 psi
Round down to 2700. Divide by three to get

NOTES

Calling a dive...

The GOLDEN RULE:

**“ANYONE CAN CALL ANY DIVE
AT ANY TIME
FOR ANY REASON”**

Example One: Same type of cylinders, but with different fill pressures.

Two divers plan a cave dive, each having aluminum 80 cu. ft. cylinders. “Diver A” has a starting gauge pressure of 3000 psi, while “Diver B” has a starting gauge pressure of 2700 psi. Since both cylinders are the same with respect to type and volume rating, you only need to identify the lowest pressure.

The diver with the 2700 psi has the least gas of the two. Thus, Diver B’s penetration gas will be what determines the other team members penetration gas as well.

Diver B’s 2700 psi divided by 3 equals **900 psi**; 900 psi will be used as the maximum penetration pressure for the team.

Subtracting 900 psi. from 3000 psi, Diver A’s turn-around pressure is **2100 psi**

Subtracting 900 psi from 2700 psi, Diver B’s turn-around pressure is **1800 psi**

If no adjustment was made for the differing gas supplies within the dive team before calculating turn-around pressures, there would be insufficient gas reserves to manage an out-of-air emergency, resulting in a potential for fatality of one or all of the team.

To further illustrate the consequences, let’s look at this scenario without adjusting for differing gas supplies .

Diver A’s starting pressure is 3000 psi: 1/3 of A’s pressure is 1000 psi; 3000 psi minus 1000 psi = 2000 psi. Diver A would turn-around at 2000 psi

Diver B’s starting pressure is 2700 psi: 1/3 of B’s pressure is 900 psi; 2700 psi minus 900 psi = 1800 psi

Thus, if Diver A had a problem that forced him to share Diver B’s gas at or after their turn-around, there may be insufficient gas for both to safely exit with. Diver B has only 900 psi in reserve for each diver, while Diver A needs 1000 psi

Metric Gas Management for same type of cylinders, but with different fill pressures (as in Example One, above).

Diver A: 210 bar Diver B: 200 bar

Diver B has the least gas and has a third or 60 bar of (200 bar rounds down to 180 bar divided by 3 = 60 bar)

200 bar - 60 bar = 140 bar turn-around

Diver A: Allowed to use the 60 bar as adjusted for the team (not 210 bar divided by 3 = 70 bar)

thus 210 bar - 60 bar = 150 bar turn-around

DIVE PLANNING & PROCEDURES (continued)

Planning Air Supply Limits (continued)

- Dissimilar cylinder sizes and starting pressure;
 - It is necessary to make an adjustment to turn-around pressures when within the team, different cylinder volumes or same volumes but different pressures are encountered. This ensures that adequate air reserves will be available.
 - Identify smallest air supply, and amount/volume available for normal safe penetration.
 - Adjust all other air supplies so that their penetration air supply is equal to or less than that of the smallest air supply.
 - When 1/3 of the smaller volume is used as the maximum penetration volume for all divers within the team. Any individual team member will have sufficient reserves for emergency exits.

Please refer to Example One, previous page, for an example of team gas planning for similar cylinders with different pressures.

Please refer to Example Two, next page, for an example of team gas planning for dissimilar cylinder sizes.

To minimize the chance of error in calculating dissimilar cylinder sizes and starting pressures, charts are included in the appendix section of this workbook.

Overall Gas Reserve Considerations

The 1/3 Air rule was established as the minimum acceptable volume for exiting a cave environment. It has become common practice among overhead divers to plan their dives so that they exit with at least 2/3rds. of their gas source. However, there are situations that reserving more than 1/3 for exiting, is far more prudent.

Maybe 1/3 is not enough!

1. Environmental Considerations

- *Low or no flow*: Requires the divers to exert energy on exit similar to that expended entering the cave. This can become tiring and cause the diver to slow down resulting in a prolonged exit, resulting in longer bottom time and requiring more gas.
- *Siphons*: Requires a greater exertion of energy to swim against the flow on the exit portion of the dive. A fatal tendency would be to proceed into the cave until 1/3 was used. The remaining 2/3 would not be sufficient to exit because of the increase effort need to swim against the flow. Additionally, there would be insufficient reserves for emergency gas management.
- *New system or entrance*: Being introduced to a new cave or cave passageway requires a more conservative gas reserve. This has a higher possibility of a prolonged exit.
- *Reduced visibility*: Slowing exit

2. Personal Considerations

- *New dive team members*: Not knowing someone's abilities or skill level should require you to be more conservative with your dive plan.
- *New dive equipment*: Can cause divers to use more gas than normal during initial use. One should become familiar with new equipment in open water before entering the cave.
- *New system*: Has a way of bringing on self-induced stress as the dive progresses. One may feel comfortable in the beginning, then as the stress builds the diver may become overwhelmed, this causes an increase in breathing, possibly consuming more than the allotted 1/3 for exit.
- *Heavy Diver traffic*: Slowing exit.

GAS REQUIREMENTS

"1/3" may not be enough! Consider:

- Lower or no flow conditions
- Possible siphon conditions
- New system or entrance
- New team members
- New equipment
- Reduced visibility
- Heavy diver traffic

Example Two: DISSIMILAR CYLINDER SIZES

Two divers planning a cave dive both have 3200 psi. fills. Diver A has a set of twin LP 95's(15 liter), while Diver B has a set of twin LP 104's(17 liter). Their respective Baseline calculations are:

Diver A / LP 95's

$$95 \text{ cf} / 2640 \text{ psi} = 0.036 \text{ cf/psi} \times 100 \text{ psi.} = 3.6 \text{ cf/ (100 psi)} \times 2 \text{ cylinders} = 7.2 \text{ cf/ (100 psi)}$$

Diver B / LP 104's

$$104 \text{ cf/} 2640 \text{ psi} = 0.039 \text{ cf/psi} \times 100 \text{ psi.} = 3.9 \text{ cf/ (100 psi)} \times 2 \text{ cylinders} = 7.8 \text{ cf/ (100 psi)}$$

Diver A (with smallest volume of gas) multiples to determine penetration volume limit for the team.

For 3200 psi fill—penetration volume is one third or 1000 psi = (10) X (100psi) penetration psi limit

Diver A will turn on 2200 psi (3200 psi—1000 psi)

$$10 (100\text{psi}) \times 7.2 \text{ cf/ (100 psi)} = 72 \text{ cf} = \text{penetration volume limit}$$

Baseline (A)

Diver B (with larger volume of gas) divides to determine amount of psi (in their twins) equal to penetration volume limit.

$$72 \text{ cf} / 7.8 \text{ cf/ (100 psi)} = \text{approximately } 9 \text{ (100psi) or } 900 \text{ psi}$$

Limit approximately 8

Baseline (B)

Diver B subtracts 900 psi from his total gas to determine his turn pressure.

$$\text{Diver B } 3200 \text{ psi—} 900 \text{ psi} = 2300 \text{ psi turn pressure}$$

Metric

**Diver A 15 liter * 2 = 30 * 210 bar = 6300 liters / 3 = 2100 liters penetration gas ,
turn pressure 140 bar**

Diver B 17 liter * 2 = 34 * 210 bar = 7140 liters

2100 liters penetration gas from diver A / 34 = 61.7 round to 61 bar

210 bar - 61 bar = 149 bar turn pressure

PROBLEM SOLVING PROCEDURES

Remember your level of training:

- Get continued education for further cave diving.
- Practice what you have learned and practice it again and again.
- On every exit, practice at least one emergency skill.
- Set limits and discuss these with your partner(s).
- During any situation, always try to avoid or minimize contact with the floor and ceiling of the cave.

Loss of Visibility (due to silting or percolation)

- Establish contact (“OK”) with the guideline.
- Turn to exit.
- Wait for contact/signals from the team member behind, then move forward to contact/signal any team member ahead.
- Utilize touch contact communication between team members while maintaining continuous contact with the guideline.
- Exit the cave.

Primary Light Failure

- Stop movement. (it may be necessary to keep moving and stay with team to utilize other team members light while deploying back up lighting)
- Reference position to guideline or establish physical contact if conditions or visibility require you to. (Maintain sense of direction).
- Activate back-up light; *this may need to be done first, in order to see guideline and to maintain control.*
- Signal your buddy that there is a problem.
- Exit the cave.

Loss of Vision (due to failure of mask)

- Secure guideline and maintain sense of direction
- Signal other team members.
- Put on spare mask.
- Stow faulty mask and exit cave as needed.

Entanglement

- Make one attempt to free self.
- Signal team members there is a problem.
- Hold position.

- Let team member free you.
- Cutting line:
 1. Make sure everyone is on exit side of cut.
 2. Secure line around area to be cut.
 3. Make cut.
 4. Re-tie, splice, or otherwise repair any guidelines that were cut (if immediately possible).
- Exit the Cavern or Cave
- Notify experienced, local cave divers of any line damage that will need additional repair.

NOTES

If you have gas to breath you have more time to handle problems. A proficient cave diver always considers where they are within a cave and how they would handle a problem at that point in the dive. You must practice problem solving skills.

Cave Conservation Note:

During any situation, always try to avoid or minimize contact with the floor and ceiling of the cave.

PROBLEM SOLVING PROCEDURES

(continued)

Lost Diver

- **Directional reference lost** (you are on the correct line):
 1. Use references such as: line arrows, current direction, visual references, marks on floor or walls, bubbles on ceiling, etc.
- **Lost Buddy** from the team (Includes lost from line, lost on wrong line or wrong direction on same line):
 1. Establish contact (“OK”) with the guideline so you do not lose it (if visibility is an issue).
 2. Stop (mark line) , try to determine buddies last known position and look for buddy’s lights (cover your light as needed).
 3. Search with your light.
 4. Re-evaluate thirds based on gas already used for penetration.
 5. Search on line– if necessary to travel off the system line a line reel must be deployed.
 6. Do not jeopardize your safety looking for a buddy that might have already exited.
 7. Exit the cave.
- **Lost guideline** (this is a very critical situation):
 1. Stop and fix position. Rise above any silt, if present and possible.
 2. Look for buddies light and look for guideline (look for the cavern exit if you are close enough).
 3. Tie off and deploy your safety reel to search for the guideline (or the exit, if close enough).
 4. References to help may include: silt trails, bubbles on ceiling, flow direction, marks on floor or walls.
 5. Secure safety reel to permanent line
 6. Exit the cave

Avoid Deep Areas

- Do not exceed maximum depth limits for your level of training or the gas mixture you have.
- Deep diving increases the need for and exposure to prolonged decompressions.
- Increased risk of nitrogen narcosis.
- Deeper depths use more breathing gas!
- Other gas related problems: O₂ toxicity, narcosis, increased decompression, etc.

GAS SUPPLY MANAGEMENT AND PROBLEM SOLVING

- **Equipment Configuration/Organization**
 1. Single cylinder with dual outlet valve (“H”, “Y” type valves).
 2. Twin cylinders with dual outlet manifold.
 - Without isolator valve.
 - With isolator valve.
 3. Twin cylinders with independent valves.
 4. Spare, stage, or safety cylinders.
 5. DIN system vs. yoke clamp system; DIN is better suited for overhead environment.
- **Recognizing Need/Problem Awareness**
 1. Degrees of need:
 - **Critical**; next breath is threatened.
 - **Immediate**; loss of gas supply will happen within minutes.
 - **Delayed**; loss of gas supply more than a few minutes away, more time to react and anticipate.
 2. Problem indicators:
 - Emergency signals from buddy.
 - Change in bubble pattern above diver.
 - Visible jet of escaping air.
 - Noise, vibration, “pop” or “bang”.
 - Rapid change on pressure gauge.

GAS SUPPLY MANAGEMENT & PROBLEM SOLVING

(continued)

NSS - CDS

• Sources of Gas Interruption or Loss

1. Problems noticed at the Second stage (usually **critical / immediate**, and self-manageable):
 - Pulled from mouth.
 - Mouthpiece separation.
 - Leakage.
 - Free flow.
 - Hose failure.
 - Accidental valve roll-shut; may be **critical**.
2. Self manageable system failures (**immediate/ delayed**):
 - Valve-to-regulator O-ring failure.
 - High/ low pressure hose rupture.
3. Team (non-self) manageable system failures (**immediate/delayed**):
 - Tank/valve O-ring failure.
 - Burst disc rupture.
 - Sheared valve handle.
(especially in combination with valve-to-regulator O-ring).
 - Damage/failure of valve/manifold
 - Overuse of supply.

Self-Management of an air failure.

1. Signal team member(s) to inform them there is a problem.
2. If loss source is evident, Diagnose and turn off valve, secure alternate regulator, if necessary.
3. If loss source is not evident, initiate **Valve Shut-down Sequence*** to diagnose.
4. Signal team member(s) for assistance if unable to resolve.

Valve Shut-down Sequence: Turn a valve off. If this does not solve problem, re-open and shut off other valve. If this also does not resolve the problem, seek assistance.

Team Management of an air failure.

1. Team member(s) signaled, asked for assistance.
2. Diver with problem given team member's alternate air source if necessary.
3. Team member assesses problem.
4. Team member then chooses among following options (depending on situation):

Option A. Turns off valve controlling air loss, restores functioning regulator to diver, initiates exit, following behind.
(touch contact as needed)

If...the manifold or dual-outlet valve is damaged, and air loss is totally uncontrollable (*See Note 1*);

Option B. If total air loss is immediately imminent, an air sharing exit (touch-contact) is initiated with the low/out-of-air diver in front and the donor's long hose deployed and under control of the receiver. (See Note 2.)

Or...

Option C. The affected diver may be allowed to exit as far as possible on the depleting air supply, with team member following behind monitoring rate of air loss, with air sharing used as needed.
(touch contact as needed)

5. Third/additional team members;
 - Provide support for affected diver and person giving direct assistance.
 - Assist in directional orientation if needed, and remain available for air sharing if necessary.

• Use of guideline during gas sharing.

1. Buoyancy control may be minimal during gas emergency, but do your best.
2. Silting, minor or severe, may easily occur.
3. Once gas emergency is under control, immediate attention must be focused on guideline and proper exit direction.
4. Whatever the donor-recipient situation, use touch contact on guideline if necessary to safely exit the cave.
5. Keep long hose under control.

NOTES

The best way to avoid problems is **prevention**. Inspect your equipment prior to the dive and perform an In Water Pre-Dive Check upon entering the water!

The best way to handle a problem is through **readiness**. Practice your emergency skills as a team as well as individually.

Note 1: If so equipped, turn off manifold isolator valve (if outlet valves are ineffective), give air-loss side regulator to diver, initiate exit, following behind in touch contact, monitoring the affected diver's rate of air loss and ensuring a safe switch to the functioning regulator when necessary.

Note 2: When it is necessary to be in touch contact with the line, the out-of-gas diver must also hold onto the donor's regulator hose to prevent it from being pulled from his/ her mouth as the team exits. Whether the line is on the left or the right side, the out-of-gas diver should hold the long hose with his/ her hand that is maintaining contact with the line. This also aids the receiving diver in a faster recovery of the regulator should it be pulled from their mouth. To recover, simply reach for the hose located in the line contact hand and follow it to the mouth piece.

Valve Shut-down Sequence:

- Close isolation valve (if so equipped **and leak is not apparent**).
- Turn right or left valve off. (listen for leaks).
- If this does not solve problem, re-open valve just closed and shut off other valve. If during process, leak stops, re-open isolator. If this also does not resolve the problem, seek assistance from team members. If leak does not stop, leave isolator closed.

CAVERN - BASIC CAVE - CAVE

NSS-CDS

Cavern

Diver

PURPOSE

This course develops the minimum skills and knowledge required for cavern (single cylinder) diving. Dive planning, cave environment, procedures, techniques, problem solving, and other specialized needs of cavern diving are covered. Accident analysis and cave conservation form the basis of the training. The dangers of unsafe practices and more advanced cave diving are discussed.

Perfecting basic skills and the mastering of techniques and procedures required for the most elementary of cave dives is the basis of this course. Cavern dives are planned around very limited penetrations so that the diver may progress into cave diving at a conservative pace.

The Cavern Diver course is not intended to train divers for all facets of cave diving.

TRAINING INTENT & COMPLETION REQUIREMENTS

This course is intended **only** to introduce individuals to the special requirements, planning, skills and develop a comfort level needed to enter a cave environment safely on a very limited and linear penetration dive. A complete and comprehensive cave diving course is required in order to proceed beyond the day light zone within the cave environment on a dive of more complex penetration of distance and multiple passageways.

- Course is designed for single cylinder diving, within the limitations described below. Only divers previously trained and experienced in double cylinder diving may utilize doubles for this course. Safety and conservation are the primary objectives of the training, not distance and speed.
- Completion of course and skill performance is determined solely by Instructor's evaluation of the student's ability, comfort and attitude. All dives and skills must be completed to the Instructor's satisfaction; the instructor reserves the right to require further training and refuse to issue training completion cards based on student performance. The successful completion of training may require more than the minimum time period and number of dives as listed in NSS-CDS standards.
- Payment of course fees does not ensure the participant of receiving a Training Completion

PREREQUISITES

Open Water Scuba Diver training. Advanced Open Water diver training or the equivalent is recommended. Students must be able to demonstrate comfort and competency in openwater skills to the Instructor's satisfaction.

COURSE OUTLINES & TEXTS

NSS-CDS Student Workbook.

NSS-CDS Cavern Diving Manual (recommended; instructor may require).

Basic Cave Diving; A Blueprint for Survival (recommended; instructor may require).

COURSE DURATION

This course usually takes two days to complete. However, course duration is determined by completion of minimum dives, bottom time and required skills. Skills are to be performed to the satisfaction of the Instructor.

NOTES

Limitations for trained Cavern Divers are recognized as:

- The daylight zone of the cavern, and always within sight of the surface entrance.
- Penetration limited to 1/3 of single cylinder or 1/6 of twin diving cylinders.
- Minimum 72 cu. ft. / 2039 liters volume tank with starting pressure of 2000 psi/ 140 bar at start of dive.
- 200 feet / 60 meters maximum distance from the surface.
- 100 feet / 30 meters maximum depth.
- 30 feet / 10 meters minimum starting visibility.
- Penetration in the daylight zone only (on a primary reel), no traverses, dives start and end at same point, no complex navigation.
- No decompression stops (safety stop as needed/prudent).
- No restrictions (areas too small for two divers to pass through together).
- No original exploration.
- No goal oriented dives.
- No solo diving.

Cavern diving is performed only within the daylight zone of any cave system that is within the limitations for this level of training.

At no time can a cavern dive be planned that would result in the loss of daylight during the dive.

A cavern without daylight is a cave!

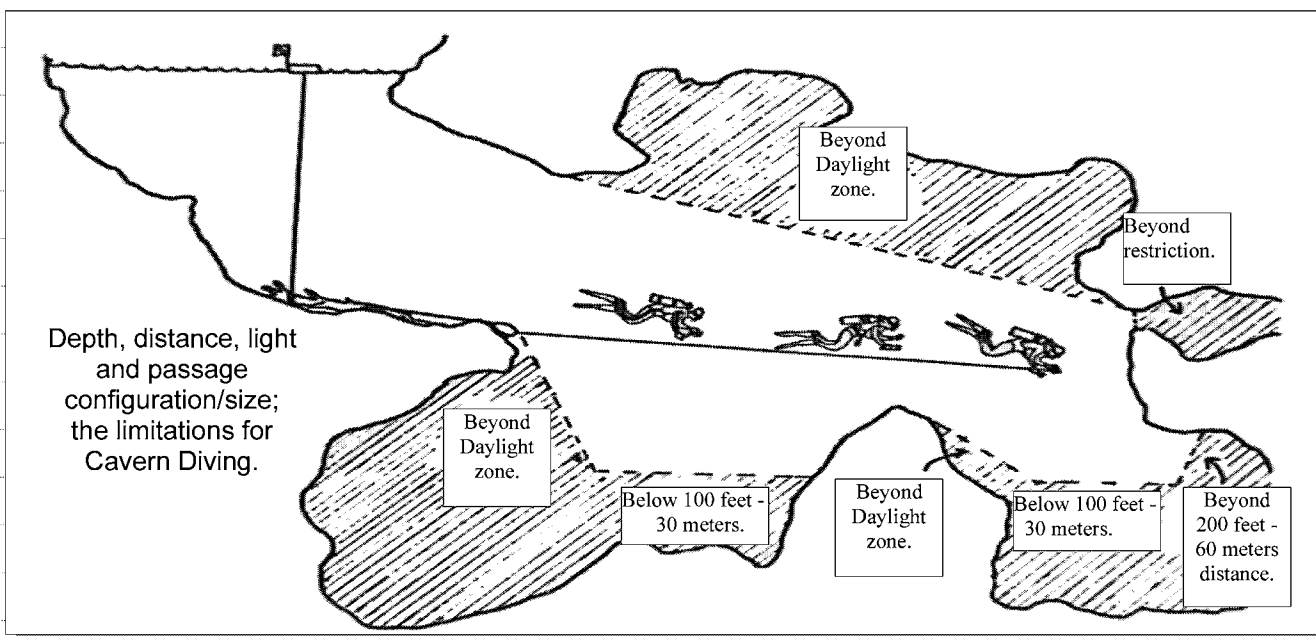

EQUIPMENT

It is recommended that each student be diving with his/her own equipment. Diving with borrowed or rented equipment tends to raise task loading and reduces proficiency during training.

- Mask and fins (straps taped is recommended), but no snorkel worn.
- At least 72 cu. ft. / 1980 liters tank
- Exposure suit suitable for time and duration at location of training.
- Buoyancy compensator (recommended type “back inflation”).
- Single cylinder with K-valve (Dual-outlet valve, with DIN-type connections recommended). Or Twin cylinders with DIN and isolator recommended.
- One first stage regulator equipped with a long intermediate-pressure hose for the primary second stage regulator. (7 foot / 2.1 meters hose recommended)
A standard low pressure hose length for a back-up second stage regulator.
- One primary battery powered diving light.
- One backup battery powered diving light.
- Safety reel/spool with minimum 100 feet / 30 meters of guideline.
- Knife or line cutter.
- Submersible pressure gauge, watch (bottom timer) and depth gauge or computer, submersible dive tables, slate and pencil.
-
- One Primary Reel per team.
- Hardware for equipment configuration/ modification (D rings, snaps, etc.)

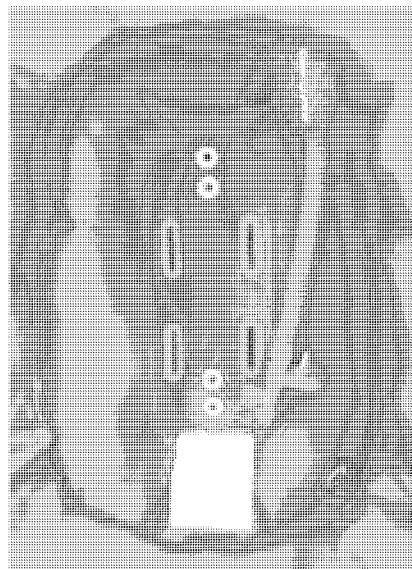
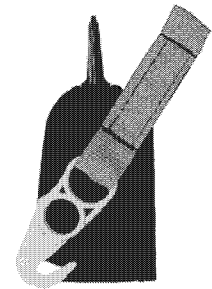
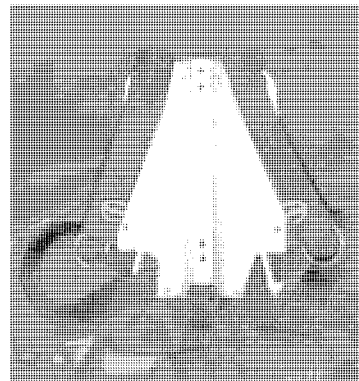
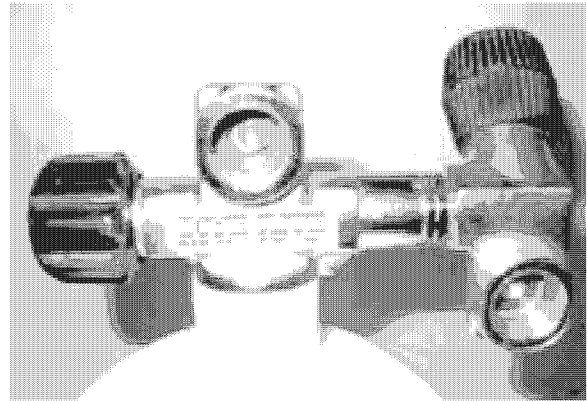

CAVERN - BASIC CAVE - CAVE

NSS-CDS Basic Cave Diver

Intro Cave Diver

PURPOSE

This course develops the minimum skills and knowledge required for cavern and limited penetration (cave diving). Dive planning, cave environment, procedures, techniques, problem solving, and other specialized needs of cavern/cave diving are covered. Accident analysis and cave conservation form the basis of the training. The dangers of unsafe practices and more advanced cave diving are discussed.

Perfecting basic skills and the mastering of techniques and procedures required for the most elementary of cave dives is the basis of this course. Cave dives are planned around very limited penetrations so that the diver may progress into cave diving at a conservative pace.

The Basic Cave/Intro Cave Diver course is not intended to train divers for all facets of cave diving.

TRAINING INTENT & COMPLETION REQUIREMENTS

This course is intended **only** to introduce individuals to the special requirements, planning, and skills and develop a comfort level needed to enter a cave environment safely on a very limited and linear penetration dive. A complete and comprehensive cave diving course is required in order to proceed within the cave environment on a dive of more complex penetration of distance and multiple passageways.

- Within the limitations described below, the Intro Cave Diver Course is designed for single cylinder diving and the Basic Cave Diver Course is designed for double cylinder diving. Safety and conservation are the primary objectives of the training, not distance and speed.
- Completion of course and skill performance is determined solely by Instructor's evaluation of the student's ability, comfort and attitude. All dives and skills must be completed to the Instructor's satisfaction; the instructor reserves the right to require further training and refuse to issue training completion cards based on student performance. The successful completion of training may require more than the minimum time period and number of dives as listed in NSS-CDS standards.
- Payment of course fees does not ensure the participant of receiving a Training Completion Card.
- The participant must properly complete all releases and forms.

PREREQUISITES

NSS-CDS Cavern Diver. Others that participate must meet all minimum skills requirements, or required skills must be performed as part of this class. The instructor has final discretion and decision in this matter.

COURSE OUTLINES & TEXT

NSS/CDS Student Workbook.

Basic Cave Diving; A Blueprint for Survival (recommended; instructor may require).

COURSE DURATION

This course usually takes two days to complete. However, course duration is determined by completion of minimum dives, bottom time and required skills. Skills are to be performed to the satisfaction of the Instructor.

NOTES

Limitations for trained Basic Cave Divers/Intro Cave Divers are recognized as:

- Penetration limited to 1/3 of single cylinder or 1/6 of twin diving cylinders.
- Minimum 72 cu. ft. / 2039 liters volume single tank with starting pressure of 2000 psi./ 140 bar at start of dive for Intro Cave and if in twin cylinders, minimum 72 cu ft/ 2039 liters volume for each tank with starting pressure of 1800 psi./ 124 bar.
- 100 feet / 30 meters maximum depth.
- 30 feet / 9 meters minimum starting visibility.
- Main line penetration only, no jumps or gaps, no traverses, dives start and end at same point, no complex navigation.
- No decompression stops (safety stop as needed/prudent).
- No major restrictions (no gear removal).
- No original exploration.
- No goal oriented dives.
- No diver propulsion vehicles in cave.
- No solo diving.

GUIDELINES

Permanent Popular Lines

- Generally, these lines are gold in color and are referred to as the “gold line”.
- Installed throughout the main passageways of frequently visited cave systems and intended to remain in place at all times. These line systems include:
 - A single main line.
 - main “trunk” lines (multiple mains).
- The main lines installed are typically thicker and stronger than that used with the primary reel. Higher traffic and/or current flow may dictate the use of stronger line.
- Offshoot lines
 - Generally these lines are white in color, and are installed in frequently visited side or offshoot passageways.
 - Requires a **Gap** or **Jump** line to be laid from the main line, to ensure a continuous line to the exit.
- Gaps, Jumps and “T’s” *
 - A **gap** is an intentional physical separation between two guidelines within the same passageway. To safely navigate from one line to the other, a temporary line (“gap/jump” reel) is installed between the ends of the two permanent lines. A gapped line typically requires minimal directional decisions.
 - A **jump** occurs when a temporary guide line is placed from the middle of one permanent guideline to the end or middle of another permanent guideline located in a different passageway. One or more directional decisions will be required when the team returns to the junction created by the jump.
 - A “**T**” intersection is where a permanent line branches, or has offshoot lines directly attached to it. One or more directional decisions will be required when the team returns to the “**T**” intersection.

• Divers at the Cavern and Basic Cave level of training are to avoid “Gaps, Jumps and T’s”.

Permanent Exploratory Lines

- Typically installed by the first cave divers to enter or survey a cave system. This guideline is typically of minimum thickness to allow the surveyor to carry a maximum amount of guideline. It is also usually knotted every ten feet. Exploratory guideline usually implies three additional characteristics:
 - All or most lines have “T’s”; there is little distinction between side passages and main tunnels.
 - Guideline is laid for best survey; person(s) installing guideline are typically very experienced cave divers and are less inclined to become entangled. These surveyors place line to make gathering of information easier.
 - Minimum quantity of directional line markers; usually found only at intersections.

Other Types of Lines

- In various parts of the world, cave divers are likely to encounter guidelines installed for a variety of different needs. Examples include;
 - Fixed “T” systems; typically seen in the Bahamas. The guidelines contain “T’s” although line systems may be a mix of diameters and/or strengths. Most intersections are marked with directional line markers, but in some locations markers are placed only at main intersections. At this level of training, it is best to avoid any “T’s”
 - Heavy-flow marine caves; where currents, usually tidal, are powerful enough to quickly destroy thin guidelines. Large diameter, braided polypropylene floating line is usually installed.

Line Markers and Their Use

Types:

- Line Arrows; design provides a directional message, typically to an exit. Important - the context of use of these markers is critical.
- Cookie; can be directionally neutral but offers a more secure attachment to line than clothespins.
- Clothespins; can be directionally neutral, may reference things other than exits.

NOTES

Some of the popular caves may have both jumps or “T’s”. It is important for cave divers to accurately mark their direction of exit so there is no navigation confusion.

Cave Conservation Note:
Permanent lines are routed so as to avoid fragile areas of the cave, and to minimize impact.

Line Arrow - Clothespin - Cookie

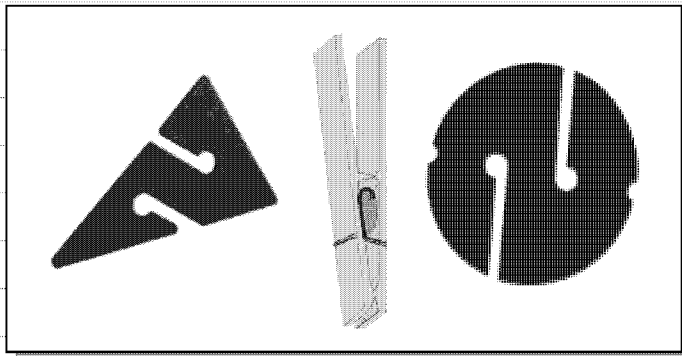

GUIDELINES (continued)

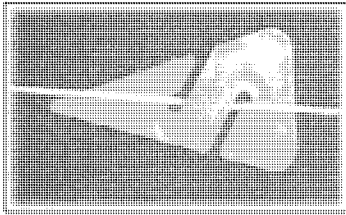

PLACED LINE ARROW

- Temporary placement. Placed on line by diver to show direction of his/her exit. The problem with this method is that it may give incorrect information to other divers in the system by referencing a conflicting direction to marked or known exit.
- Arrow subject to movement.

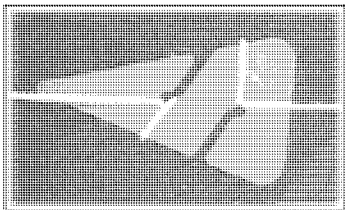

LOCKED LINE ARROW

- Secured placement. Placed on line to show established direction of exit on permanent installed lines. May also indicate location of side passageways. Method also used by diver(s) for a secure attachment to the permanent line when leaving the permanent line with a reel.
- Arrow less likely to move if disturbed.

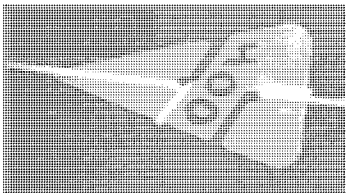

DISTANCE MARKER

- Secured placement with numbers in feet or meters to known exit. Placed on line to show direction and distance to established exit. Use caution, as actual distances may not be accurate due to line repairs.

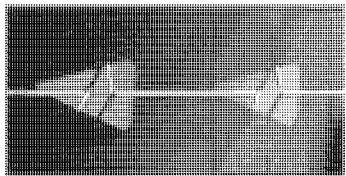

DOUBLE LOCKED LINE ARROWS

- Secured placement using two arrows. Placed on main line to show direction and also indicate the location of popular intersecting passageway(s). Tie-off may be made between arrows to help ensure placement.

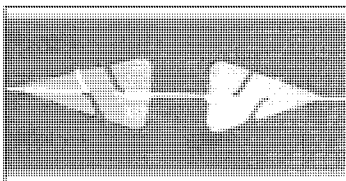

DOUBLE LOCKED LINE ARROWS / Opposing Direction

- Secured placement indicating mid-way-point to exits. Placed on line when appropriate, to show direction and indicate equal distance to an exit from that point. Use caution, as actual distances may not be accurate due to line repairs.

Basic Cave/Intro Cave Diver

EQUIPMENT

It is recommended that each student be diving with his/her own equipment. Diving with borrowed or rented equipment tends to raise task loading and reduces proficiency during training.

- Mask and fins (straps taped is recommended), but no snorkel worn.
- At least 70 cu. ft. / 1980 liters of gas at the start of the dive.
- Exposure suit suitable for time and duration at location of training.
- Buoyancy compensator (recommended type “back inflation”).
- Single cylinder with dual-orifice “Y” or “H” valve (DIN-type connections recommended) or twin cylinder configuration (verify with instructor).
- One first stage regulator equipped with a 7-foot / 2.1 meters intermediate-pressure hose.
- One first stage regulator equipped with a standard length intermediate-pressure hose.
- One primary battery powered diving light.
- Two backup battery powered diving lights.
- Safety reel/spool with minimum 100 feet / 30 meters of guideline.
- At least three (3) line markers (cookies or plastic line arrows).
- Knife or line cutter.
- Submersible pressure gauge and dive computer . or submersible pressure gauge, watch (bottom timer) and submersible dive tables.
- One (1) primary cave-diving reel with approximately 400 feet / 125 meters of guideline.
- Appropriate hardware for equipment configuration/ modification. (D rings, snaps, etc.)

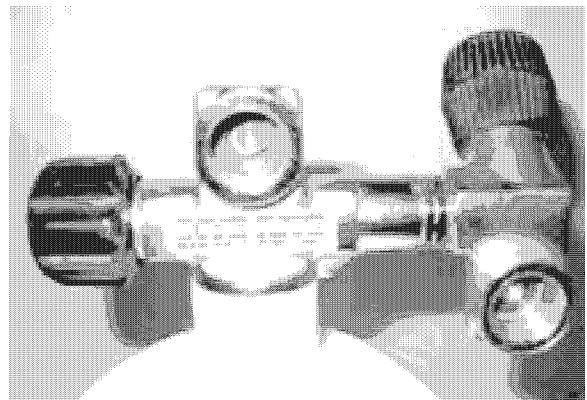
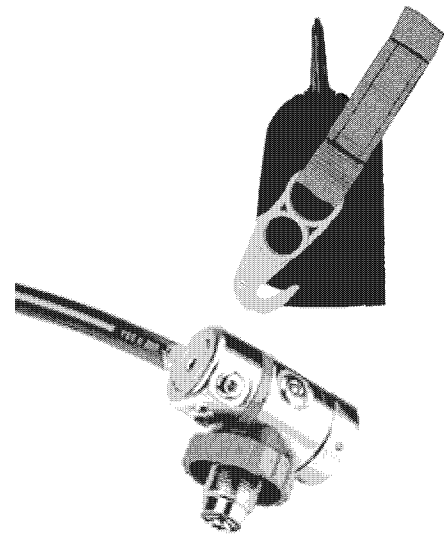
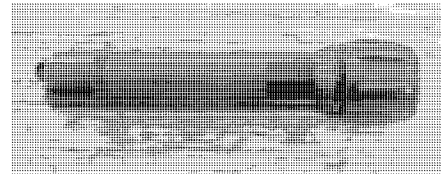

CAVERN - BASIC CAVE - CAVE

NSS-CDS
Apprentice
Cave
Diver

PURPOSE

This is the third in a series of cave diver development training courses. Emphasis is on dive planning and skill perfection through actual cave dives. Techniques learned through the earlier Cavern Diver and Basic Cave/Intro Cave Diver courses are critiqued and expanded. Exposure to different cave-diving scenarios is the foundation of this training. Cave environment awareness and the consequences of diver impact relative to new diving scenarios is discussed.

The Apprentice Cave Diver course level represents the first half of the training ultimately required to complete the Cave Diver level, and is not intended to prepare divers for evaluating all facets of cave diving; a **time-limited training** card is issued upon completion. It is intended to expose students to basic fundamental principles of cave diving. Students are encouraged to move on to the next level of training before attempting to plan and execute complex cave dives.

The Apprentice Cave Diver course can be combined with the Cave Diver course.

TRAINING INTENT & COURSE COMPLETION

This course is intended **only** to introduce individuals to the special requirements, planning, and skills necessary to develop a comfort level needed to enter a cave environment safely on a very limited penetration dive. A complete and comprehensive cave diving course is required in order to proceed within the cave environment on a dive of more complex penetration of distance and multiple passageways.

- Course is designed for double cylinder diving, within the limitations described. Safety and conservation are the primary objectives of the training, not distance and speed.
- Completion of course and skill performance is determined solely by Instructor's evaluation of the student's ability, comfort and attitude. All dives and skills must be completed to the Instructor's satisfaction; the instructor reserves the right to require further training and refuse to issue training completion cards based on student performance. The successful completion of training may require more than the minimum time period and number of dives as listed in NSS-CDS standards.
- Payment of course fees does not ensure the participant of receiving a Training Completion Card.
- The participant must properly complete all releases and forms.

The Apprentice Cave Diver training completion card that is issued upon successful completion of this level of training is a time-limited credential only.

This training completion card will expire (become invalid) exactly one (1) year from the date that it is issued.

PREREQUISITES

NSS-CDS Basic Cave/Intro Cave Diver or equivalent. **Decision of entrance to this level of training is determined by the Instructor.**

NOTES

Limitations for trained Apprentice Cave Divers are recognized as:

- Penetration limited to 1/3 of twin diving cylinders. (No stage diving.)
- Minimum volume at start of a dive is 140 cu. ft. / 3960 liters.
- 130 feet / 40 meters maximum depth.
- 20 feet / 6 meters minimum starting visibility.
- Simple penetrations only (limited to one jump); no complex navigation plans, including circuits or traverses, dives start and end at same point.
- PO₂ not to exceed 1.4 ATA. (1.6 ATA @ deco stops).
- Limited decompression stops (dive plan should minimize deco obligations).
- No major restrictions (No gear removal in cave).
- No original exploration.
- No goal oriented dives.
- No use of diver propulsion vehicles in caves.
- No Solo Diving

Decompression Stop Logistics (for the Apprentice Cave Diver)

Limited decompression stops at the Apprentice level are allowed in order for students at this level to safely plan and conduct cave dives involving the bottom times often associated with the use of double cylinders. It is expected that students at the apprentice level of training are capable of , and should, plan dives with optimum choices in breathing gases and decompression planning. The actual stop times are determined by several factors.

- **Breathing gas choices**
 - Back gases
 1. Air
 2. Nitrox
 - Decompression gases
 1. Air
 2. Nitrox
 3. High O₂ mixes– 50%, 80% or 100%
- **Decompression planning**
 - Dive tables
 - Dive computers
 1. Air
 2. Nitrox compatible
 3. Multi gas

DECOMPRESSION CONSIDERATIONS

All dives are to be planned as a no-decompression dive at the Cavern and Basic Cave Level. Decompression diving is not in the scope of training until the Apprentice / Cave level of the program. This section is only a review of the basics of breathing compressed gasses while scuba diving and the effects on human physiology as learned in your previous scuba training.

This section is only intended as an outline to be used in conjunction with training by your NSS-CDS Instructor.

Any scuba dive has the potential of resulting in an incident of decompression sickness (DCS), despite proper and correct planning procedures by the divers. However, some forms of scuba diving present a higher risk than others. Cavern and cave diving are among those considered to be high risk. This is primarily due to the fact that the divers do not have a direct access to the surface. The very nature of cavern and cave diving requires a diver to be in an overhead environment. This can cause a delay in surfacing, resulting in a longer bottom time than was planned. The result may involve a decompression requirement for which the divers may not have planned nor have sufficient gas reserves for. Some reasons for possible delays:

Loss of visibility
Lost buddy
Lost line
Air sharing
Disorientation from exit
Siphons/flow
Fatigue

Another reason cavern and cave diving is a greater risk is that most of the sites require a greater physical effort to enter and exit the water. This characteristic presents two hazards:

Dehydration and Exertion

This is due to physical demands on the divers body

while transporting dive gear to and from the dive site. Usually wearing an exposure suit, the diver can quickly become dangerously overheated. At the exit of the dive the diver exerts more energy to climb out of the water and sinkhole. This can increase the risk of DCS for the diver.

Cold

Water temperatures colder than body temperature will result in a loss of body heat. This will subsequently result in changes in blood flow to different tissues. Water temperature, type of exposure suit, and exposure time will increase DCS risk.

BREATHING GAS CHOICES

1. AIR–

A. Advantages

- Longest history of use..
- Flexible depth range.

B. Disadvantages

- Poor decompression gas.
- Narcosis at depth.
- Longer decompression schedules.

2. NITROX– Oxygen enriched air

A. Advantages

- Increased no decompression limits.
- Shorter decompression times.
- Excellent decompression gas to aid off gassing after air dives.

B. Disadvantages

- Depth limited– dependent on O2 percentage.
- Requires gas analysis before each dive.
- Cylinders and equipment must be properly cleaned and labeled.

3. MIXED GAS– alternate inert gas blends usually utilizing helium Trimix and heliox blends popular beyond 130’.

A. Advantages

- Decreased inert gas narcosis effects.
- Decreased Oxygen toxicity levels.
- Increased diver performance at depth.

B. Disadvantages

- Need multiple gas mixes (travel & deco).

DECOMPRESSION CONSIDERATIONS (CONTINUED)

- Must be blended for specific depths.
- Careful marking of cylinders is required.

• CNS OXYGEN TOXICITY

Central nervous system toxicity is a human physiological response to increased exposures of breathing elevated partial pressures of oxygen (O₂). The importance of this to divers is that high exposures may cause an oxygen seizure which usually results in drowning while underwater.

- Considered short term-high dose
- Often referred to as Paul Bert effect.
- NOAA has defined limits up to 1.6 PPO₂.
- “Working” dive limit of 1.4 PPO₂ should not be exceeded and may even be reduced due to circumstances of dive profile.

It is essential that all gas cylinders are marked with the gas contents and the Maximum Operating Depth (M.O.D.)

- “Deco/ stop” dive limit of 1.6 PPO₂ is common.

• DECOMPRESSION SICKNESS (DCS)

When a diver’s blood and tissues have taken up nitrogen or helium in solution at depth, reducing the external pressure on ascent can produce a state of super saturation. A dissolved gas can have a tension higher than the total pressure in the body. If the elimination of dissolved gas, via the circulation and the lungs, fails to keep up with the reduction of external pressure, the degree of super saturation may reach the point at which the gas can no longer stay in solution.

If a tissue is supersaturated with gas to this degree, the gas eventually separates from solution in the form of bubbles. The situation then resembles what happens when a bottle of carbonated beverage is uncapped. Bubbles of nitrogen forming in the tissues and blood result in the condition known as decompression sickness. These bubbles can put pressure on nerves, damage delicate tissues, block the flow of blood to vital organs and induce biochemical changes and blood clot-

ting.

Fortunately, the blood and tissues can hold gas in supersaturated solution to some degree without serious formation of bubbles. This permits a diver to ascend a few feet without experiencing decompression sickness, while allowing some of the excess gas to diffuse out of the tissues and be passed out of his body. By progressively ascending in increments and then waiting for a period of time at each level, the diver eventually reaches the surface without experiencing decompression sickness.

• DCS– TYPES

1. TYPE 1 DCS

A. Musculoskeletal symptoms

- Most common
 - Typically pain in joints
 - May also affect joint muscles
- ##### *B. Cutaneous (skin) symptoms*
- Itching is common
 - Rashes, mottling or “crackling” of skin
 - Lymphatic obstruction or swelling

2. TYPE 2 DCS

A. Neurological symptoms

- Numbness, tingling, decreased sensation to touch
- Muscle weakness or paralysis
- Unusual fatigue
- Urinary function disruption
- Vertigo, dizziness, ringing in ears
- Change in personality or sex drive

APPROXIMATELY 85% OF SYMPTOMS WILL OCCUR WITHIN ONE HOUR WITH APPROXIMATELY 85% OF THOSE SYMPTOMS OCCURRING AS ARM OR LEG JOINT PAIN.

If DCS is suspected DON'T be in denial! Administer 100% O₂ as first aid and call 911 or Divers Alert Network for treatment information

DECOMPRESSION CONSIDERATIONS (continued)

• DCS– CONTRIBUTING FACTORS

1. **DEPTH**– The deeper the dive the greater the pressure and partial pressures of the breathing gases which increases the inert gas absorption

2. **TIME**– The longer the time at a given depth with a given exposure to elevated partial pressures the more absorption into the body

3. **ABSORPTION**– The rate at which different tissue “compartments “ absorb the inert gases is the subject of many hypothetical models used in modern dive computers, software and dive tables.

4. **ASCENT RATE**– Since it is necessary for the body to have the time to off gas the absorbed inert gases, the speed of ascent must be a controlling factor in the planning of a safe dive.

An Ascent rate of 30 feet per minute is the maximum recommended rate of ascent!

5. DCS– PREDISPOSING FACTORS

A. **DEHYDRATION**– excessive loss of fluids accompanied by a disturbance in the balance of essential electrolytes. Caused by:

- Excessive perspiration.
- Immersion diuresis causing urination.
- Drinking alcohol.
- Breathing compressed gases.
- Sea sickness.

B. **EXERTION**– excessive exertion before, during, and after the dive

- Causes build up of carbon dioxide (CO₂).
- Exertion during the dive speeds up circulation and absorption of inert gases.
- Causes trapping of gas and bubbles production.

C. **PHYSICAL FITNESS**– any factor contributing to impaired circulation such as:

- Age of diver.
- Old injuries.
- Obesity or over weight.

D. **FATIGUE**– tired divers are more likely to experience a DCS hit in addition to having impaired judgment.

E. **COLD**– besides being uncomfortable cold shunts the circulation system delaying the off gassing of the extremities.

F. **EQUIPMENT ISSUES**– equipment in anyway impairing circulation such as tight webbing or shoulder straps, dry suit wrist seals, etc. delay off gassing

• DCS– TREATMENT

Treatment of decompression sickness is accomplished by recompression. This involves putting the victim back under pressure to reduce the size of the bubbles to cause them to go back into solution and to supply extra oxygen to the hypoxic tissues. Treatment is done in a decompression chamber.

NOTES

A safety stop is recommended after every dive within the No-Decompression Limits.

- Traditional stop— minimum 3-5 minutes at 15-20' stop
- RGBM stop- one minute at 1/2 of maximum depth and two minutes at 15-20' stop

RGBM or it's full name of Reduced Gradient Bubble Model is a popular decompression model that takes into consideration bubble dynamics in addition to dissolved gas modeling. It suggests that tissue damage can be lessened by incorporating deep stops into the ascent profile.

A surface decompression stop of after every dive is recommended after every dive within the No-Decompression Limits.

A surface decompression stop is a stop that is done at the surface that is addition to any actual stops determined by dive tables and/ or dive computers. It allows the body extra time to off gas nitrogen or other inert gasses before any strenuous activity such as exiting the water with heavy dive gear.

This can easily be accomplished by having the team debrief the dive before exiting the water.

While typical recreational dive tables accept a minimum surface interval of ten minutes between dives it is recommended that a minimum one hour surface interval be planned

EQUIPMENT

All gear listed in the Basic Cave Diving course with the following additions and exceptions:

- Twin-diving cylinders with a minimum starting volume of at least 140 cu. ft. / 3960 liters are now required. Dive cylinder configuration may consist of any twin cylinder configuration agreed to by the instructor and student (s).
- Primary light with appropriate intensity and burn time for the dives planned. The instructor reserves the right to establish minimum intensity (bulb wattage) and burn time (battery charge longevity) for dives conducted under that instructor's control.
- At least (1) jump/ gap reel with minimum 50' / 16 m of guideline (100' / 33 m recommended).
- It is recommended that each team will provide an in-water decompression cylinder properly identified, on all dives in which staged decompression may become a factor. The cylinder(s) will incorporate all necessary support gear including, but not limited to: regulators(s) and submersible-pressure gauge(s). The cylinder(s) will contain adequate gas for at least 1.5 times the expected decompression needs of the dive team, and should be placed in a safe and suitable location.
- Compass (optional).

Additional equipment and equipment modifications are required before attempting to cave dive safely.

The NSS-CDS strongly suggests that each student have their own equipment at this level of training, to help reduce *Task Loading* due to the unfamiliarity of equipment and equipment placement.

Equipment modification includes adjusting the placement of D-rings and other attachment points to accommodate the size of the diver and ensure streamlining.

This also ensures ease of deployment and recovery of gear. If gear is rented or borrowed, these modifications may not be an option.

There are several methods, reasons, and styles of modification to the cave diver's equipment. Some more practical than others. . All too often divers modify their gear because of a specific problem without consideration to the effect that change might have as a result of the modification. When attempting to modify your gear, always ask yourself "if I make this change what else will it effect?"

Before attempting modifications to your gear prior to class, consult with your Instructor for his/her expertise. And, remember to consider the effect it might have.

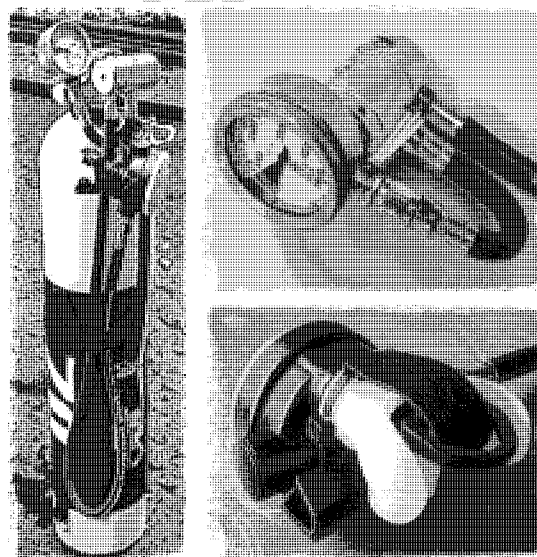
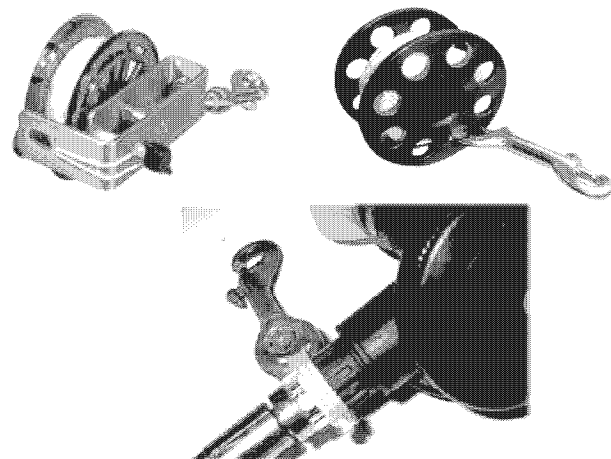

NOTES

Horizontal lines for note-taking.

DECOMPRESSION DIVING PROCEDURES

It is highly recommended that anyone considering the conduct of a dive requiring staged decompression be properly trained and fully understand the principles, procedures and hazards involved. Decompression Diving is considered extremely hazardous. The risk of bodily injury and death can be minimized by proper training but not eliminated. The use of proper procedures and care are essential for your survival. The Cave Diving Section of the NSS does not encourage, condone, or promote diving beyond the no-decompression limits without the proper training and implementation of such training.

General Practices and Precautions

- Emergency oxygen must be on-site and available when dives are expected to exceed 80% of the No Decompression limits.
 - Surface decompression* will be conducted anytime 80% of the No-Decompression limits have been exceeded.
- *Surface decompression is time spent at rest on the surface, prior to exiting the water. It must be at least 1/2 of the decompression time required at ten feet or five minutes whichever is longer. Anytime that the exit requires strenuous exertion additional surface decompression should be conducted. It is generally recommended that the post dive de-briefing be conducted during surface decompression.
- Drinking fluids (water, Gatorade, etc) should be available, to prevent dehydration.
 - Body warmth. Procedures should be established to prevent to loss of body heat during and after the dive.
 - Dive sites in which the diver must descend **after** completing part or all of the required decompression, prior to the ascent to the surface, are prohibited.

- Safety (stage) cylinders will be properly rigged with a first stage regulator, a second stage regulator, a submersible pressure gauge and will be properly marked for the Maximum Operating Depth (MOD).

Gas Management for decompression

Anytime that required decompression is planned, gas must be reserved to accomplish it safely. That gas which is reserved for decompression is specifically prohibited from being used in planning the rule of thirds for penetration.

- It is recommended that each person place a decompression cylinder in the water one stop-depth deeper than the first planned stop, containing 150% of the individual team members decompression gas requirements of the dive plan.
- The absolute minimum acceptable decompression gas supply in a placed fashion will be a properly rigged cylinder containing least 150% of the decompression gas needed for the entire team. (if a single bottle is intended to supply the entire team a suitable number of second stage regulators is required).

If safety cylinders are not available, the following procedure can be used as a planning alternative.

- Decompression on Back Gas: Each team member must reserve 150% of the decompression gas requirements of dive plan. This amount will be subtracted from the starting pressure prior to calculating 1/3's.

Example: If the smallest volume on the team has a starting pressure of 3300 psi in a set of low-pressure steel 95 cu. ft. tanks, and the person with the highest RMV will consume 150 psi (of that supply) during decompression, then 225 psi must be reserved for decompression. Subtracting 225 psi from the starting pressure leaves 3075 psi for the calculation of thirds. The resulting Critical Air Supply is 1000 psi, resulting in a turn pressure of 2300 psi for that set of cylinders.

NAVIGATION PROCEDURES

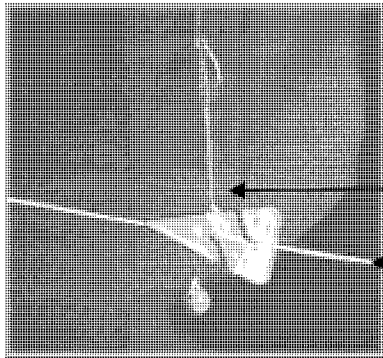

T'd into permanent line and locked arrow.

Permanent line.

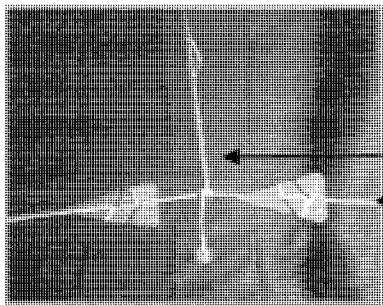

T'd into permanent line between locked arrows.

Permanent line.

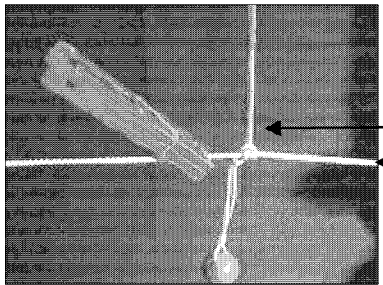

T'd into permanent line. Clothespin marks direction of exit.

Permanent line.

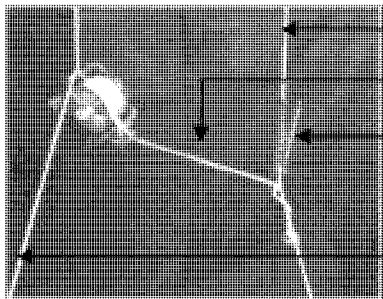

Permanent line A.

Jump line.

T'd into permanent line. Clothespin marks direction of exit.

Permanent line B.

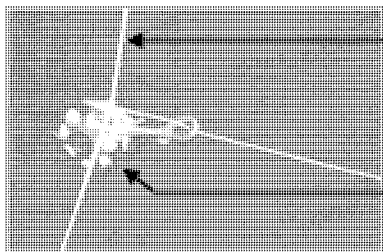

Permanent line.

Spool tied off to secondary line.

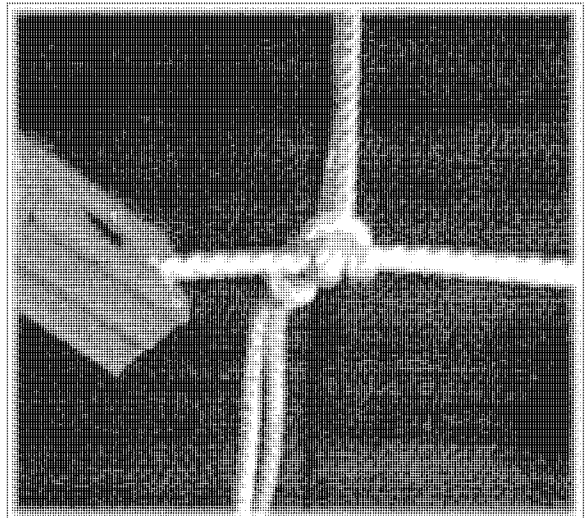

CAVERN - BASIC CAVE - CAVE

NSS-CDS
Cave
Diver

PURPOSE

This is the fourth in a series of cave diver development training courses. Exposure to more sophisticated cave-diving scenarios are the foundation of this training. Complex cave dive planning and execution is emphasized. Techniques learned during the previous training levels are refined in more challenging cave diving environments, along with their proper application in minimizing diver impact to the cave. Developing a comprehensive awareness of the cave environment and its full implications to cave conservation efforts and practices is emphasized.

Techniques and protocols to maintain continuous line and navigational certainty to the exit in more complex cave-diving scenarios than those faced in earlier training; line jumping and gapping and their potential and/or actual application to circuits and traverses (when appropriate), and; ensuring safe air supply and reserves during all travel.

TRAINING INTENT & COURSE COMPLETION

This course is designed for twin cylinder diving, within the limitations described. Safety and conservation are the primary objectives of the training, not distance and speed.

The Cave Diver training completion card that is issued upon successful completion of this level of training is not a time-limited credential. Therefore, it does not expire. However, in order to maintain the high level of skill, proficiency and comfort required to plan and execute a cave dive. You should cave dive often. If there has been a long lapse since your last cave dive, have a Cave Instructor review your skills.

- Completion of course and skill performance is determined solely by Instructor's evaluation of the student's ability, comfort and attitude. All dives and skills must be completed to the Instructor's satisfaction; the instructor reserves the right to require further training and refuse to issue training completion cards based on student performance. The successful completion of training may require more than the minimum time period and number of dives as listed in NSS-CDS standards.
- Payment of course fees does not ensure the participant of receiving a Training Completion Card.
- The participant must properly complete all releases and forms.

PREREQUISITES

NSS-CDS Apprentice Cave Diver (entrance to this level is at the discretion of the instructor).

COURSE OUTLINES & TEXT

NSS-CDS Student Workbook.

COURSE DURATION

This course usually takes at least two days to complete. However, course duration is determined by completion of minimum dives, bottom time and required skills. Skills are to be performed to the satisfaction of the Instructor.

NOTES

Limitations for trained Full Cave Divers are recognized as:

- Penetration limited to 1/3 of twin diving cylinders.
- Minimum volume at start of a dive is 140 cu. ft. / 3960 liters.
- 130 feet / 40 meters maximum depth.
- 20 feet / 6 meters minimum starting visibility.
- PO₂ not to exceed 1.4 ATA. (1.6 ATA @ deco stops).
- Limited decompression stops **during training**.
- No major restrictions (No gear removal in cave) **during training**.
- No goal oriented dives.
- No use of diver propulsion vehicles in caves.

It is required that additional training in the use of diver propulsion vehicles, stage diving, deep cave diving, rebreathers or side-mount configurations be sought before attempting their use.

While the basic principles of use can be learned by observing others, training with your NSS-CDS instructor will emphasize the proper skills required to minimize the damage to the often fragile cave environment. In addition, specialized training will emphasize the special safety skills required that can not be learned by watching others in normal situations.

EQUIPMENT

All gear listed in the Apprentice Cave Diving course.

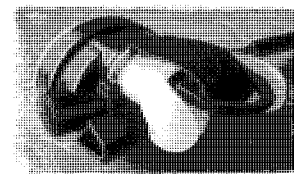
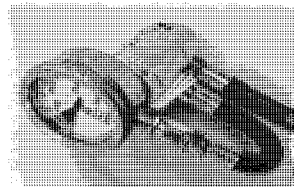
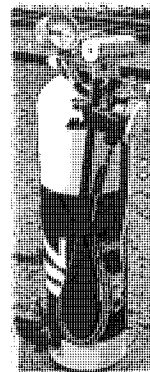
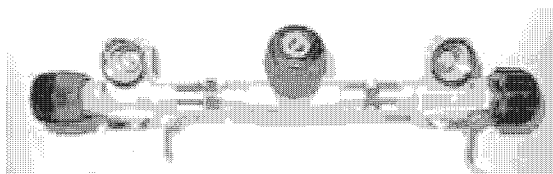
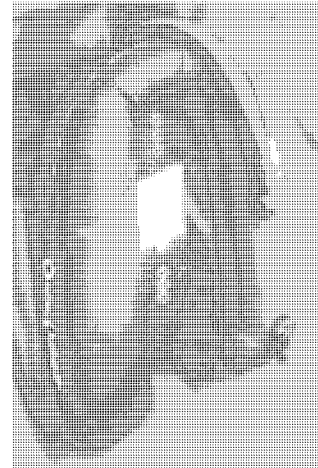
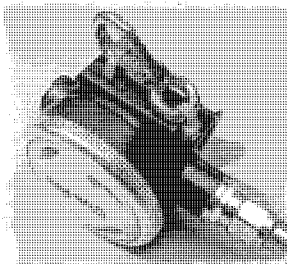
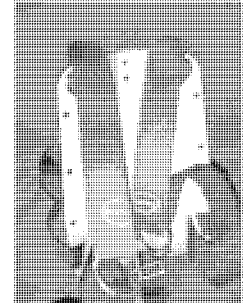
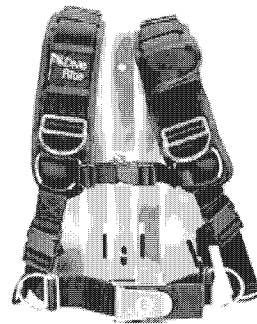
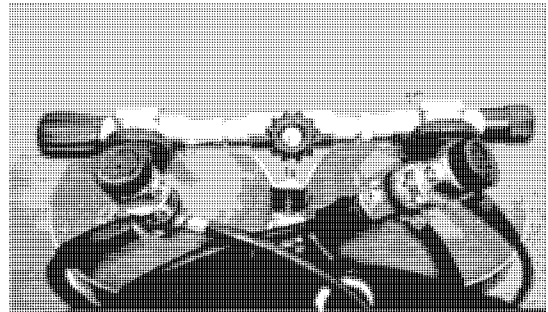
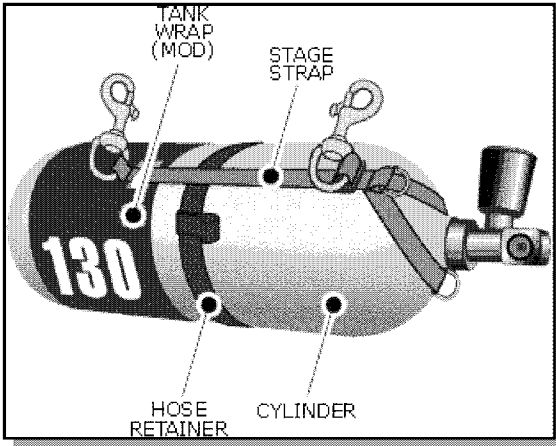

Underwater Cave Surveying Introduction

UNDERWATER CAVE SURVEYING

INTRODUCTION TO UNDERWATER CAVE SURVEYING

Original Outline Prepared by James Coke, NSS 26442

Underwater cave surveying is one of the most satisfying activities in cave diving. Not only does it serve as an enjoyable diversion, it is also a significant tool, which cave divers use to understand and document the cave environment. Without surveying, exploration becomes chaotic and meaningless. By creating maps we all share in a priceless contribution to cave diving.

MOTIVES FOR SURVEYING

Positive landowner relations

- Involves landowner with your activities.
- Landowners can grow to understand your desire to explore their cave.
- Fosters friendly relationship which keeps cave site open.
- Useful for landowners in finding well sites or protecting their aquifer against pollution.
- Documents geological hazards.

Enriches cave awareness

- Increases ability to plan safe explorations.
- Provides knowledge of location in the cave at any time.
- Aids in judging distance from exit(s).
- Assists in planning safe air reserves.
- Helps your appreciation of the cave grow.

Exploration advantages

- Documents exploration.
 - Invaluable for team surveying effort.
 - Share data with mappers already surveying a cave.
- Helps locate areas of possible leads, other cave entrances, or connections between systems.
 - Cave surveyors map surface terrain to interpret the cave's position.
 - A cave is never truly explored unless a survey and map are done.
- Promotes team spirit among cave diving community.

Scientific benefits

- Present and future studies of caves need maps.
- Promotes integrity of cave diving.

GRADES OF SURVEY

Grade 1

- A sketch from memory.
- All measurements estimated.
- Shows general trend of cave.
- As accurate as the memory of the draftsman.

UNDERWATER CAVE SURVEYING (continued)**Grades 2 to 3**

- A simple line survey.
 - Depth of each survey station (where survey line changes direction) taken by a non-digital depth gauge.
- One compass bearing (azimuth) taken at each survey station.
- Survey line knotted every 10 feet / 3 meter for distance measurement between survey stations.
 - Each complete 10 feet / 3 meter segment counted while portions of 10 feet / 3 meter segments estimated.
 - Line used to make tie-offs or wraps not counted.
 - Survey data generally collected on exit when exploration line is in position.
- Basic yet rapid means of surveying.
 - Not as accurate as a Grade 4 to 5 survey .
 - Used when time or depth does not allow a Grade 4 or 5 survey.
 - One surveyor can collect all survey data.
 - Expect possible large errors.

Grades 4 to 5

- A survey which employs specialized equipment.
 - Survey station depth collected with digital depth gauge or other device accurate to 1 foot / 0.3 meter.
 - 2 azimuths (foresight and backsight) collected by precision compass.
 - Distances between survey stations measured by fiberglass tape.
- Multiple dives needed for data collection.
 - Wall measurements.
 - Room diameters.
 - Important features of cave passages recorded.
- A complicated and slower survey process.
 - Data collected is more accurate than Grade 1 to 3 survey process.
 - Two surveyors needed to collect survey data.
 - Prospect of team separation while measuring survey station distances with tape.
 - Communication between survey team becomes more difficult.
 - Air reserve planning for longer dive time and decompression.
- High precision maps produced from these surveys.

SPECIAL EQUIPMENT FOR UNDERWATER CAVE SURVEYING**Underwater compass**

- Desirable features.
 - Compass card marked in 5 degree increments or less.
 - Luminescent compass card makes it easy to read.
 - Liquid filled.

UNDERWATER CAVE SURVEYING (continued)**SPECIAL EQUIPMENT FOR UNDERWATER CAVE SURVEYING****Underwater compass (continued)**

- Compass types
 - Compass with a square body.
Side reading compass uses a "look through" feature.
Other compasses use "look down" feature or lockable bezel.
 - Compass without square body.
Both side reading and "look down" styles.
"Look down" style is slate mounted to provide straight edge to lay against survey line for azimuth.
 - Digital compass .

Equipment for measuring distance

- Knotted line
 - Used for Grade 2 to 3 surveys.
 - Use care when knotting line.
 - Source of survey error.
- Diver's body
 - Body spans estimate long portions of knot segments.
 - Arm spans estimate small portions of knot segments.
- Fiberglass tape
 - Needed for Grade 4 to 5 surveys.
 - 100 foot model in a plastic case preferred; should have foot scale in 10ths and 100ths on one side (no inches), metric on the other.
 - Do not leave in the sun.
- Hand-held sonar unit.

Slate to record data

- Fixed in an orderly fashion.
- Easy to read fill in blanks for recording data.
 - First column: Station number.
 - Second column: Depth.
 - Third column: Azimuth.
 - Fourth column: Distance.
 - Fifth column: Sidewall information
Station 0 below lists line on left wall.
Station 1 below lists line on right wall.
 - Sixth column: Comments.
Station 0 below notes silty conditions.
Cave configuration, possible offshoot passages, rooms etc.
can be recorded here.
- See included list of map symbols.

UNDERWATER CAVE SURVEYING (continued)**SPECIAL EQUIPMENT FOR UNDERWATER CAVE SURVEYING****Slate to record data (continued)**

- Typical example of slate after a Grade 3 survey

Sta	Dpth	Azm	Dist	S	C
0	67	274	3.3	<	S
1	54	291	5.2	>	
2	45	326	1.7		
3	35				

SURVEYING PROCEDURE**Routine**

- Collect data from instruments in a systematic order and record in a uniform manner.
 - Pattern of data collection is established.
 - Recording data becomes second nature.
 - Write from left to right in same row.
 - Less chance for survey errors by using routine.
 - Record Depth of station first .
 - Record Azimuth of surveyed line second.
 - Shoot azimuth second time to confirm first reading.
 - Record Distance of surveyed line third.
- Sequence of survey data on slate in same order as surveyed line.
 - Data easily reversed if necessary.
 - Mistakes quickly detected.
- Record depth of the last survey station.
 - Vital for converting raw data to plan (road map) view during map plotting.
 - Essential when connecting new survey to existing survey.

New survey merge to old survey line

- Link new survey data to nearest established old survey station.
 - New survey data useless without a tie-in.
 - Avoid new survey tie in between two stations.
- From established old survey station.
 - Record depth of tie in station.
 - Record two azimuths from tie in station.
 - Line heading into cave.
 - Line heading out of cave.
 - Record one distance measurement to next old survey station.

UNDERWATER CAVE SURVEYING (continued)**SURVEYING PROCEDURE***(continued)***Before exiting water**

- Verify legibility of your handwriting on slate.
- Mark slate whether survey was taken on the way in or out of the cave.

Applications

- Routine compatible with computer aided survey management.
- Procedure compatible with any grade survey.

CONSIDERATIONS FOR DEGREE OF DETAIL ON MAPS**Size of cave**

- Large caves versus small caves.
 - Detail feasible in either case.
 - Large caves require more survey dives.
 - Small caves need detail to perfect map.
- Select desirable map scale.
 - Detail is a slave to map scale.
 - Select best size of drawing paper to fit scale.

Depth of cave

- Limiting factor when gathering detail.
 - Air supplies.
 - Decompression factors.
- Diver impairment at depth.
 - Inert gas narcosis.
 - Task loading corrupts team safety.

Time in cave

- Limiting factor at depth.
 - Air supplies.
 - Decompression factors.
- Long penetrations.
 - Survey time is limited.
 - Long dives impair ability to collect detail.
 - Task overloading.
 - Fatigue.

Logistics to reach cave

- Short land journey versus strenuous land journey.
 - Transporting heavy equipment to cave site.
 - Hot or cold climate.
- Access to water.
 - Water same level as surface terrain.
 - Rope needed to get in/out of water.

NOTES

To Create a Simple Map Plot:

- Tools needed:
 - Calculator
 - Circular protractor
 - Ruler
 - Graph paper (ex. 10 to 1 grid squares)
- Establish a scale.
(Example: 1 grid = 50 feet / 15 meters).
- Establish a Magnetic North arrow.
- Select beginning point to plot line survey.
- At beginning point mark azimuth with protractor.
- With ruler draw from protractor center along the azimuth for corrected distance to next station.
- Repeat for next station using end of distance point from previous station.
- When line plot is complete, draw cave walls and other interesting features.
- Add appropriate map symbols where useful.
- End result:
 - your map of the cave.

UNDERWATER CAVE SURVEYING (continued)**CONSIDERATIONS FOR DEGREE OF DETAIL ON MAPS***(continued)***Survey team commitment**

- Long or short term projects.
- Safety versus information.
 - Team safety of primary importance.
 - Accuracy of line survey secondary.
 - Detail subordinate.

Purpose of map

- Tool to reveal further exploration and trends.
- Completed as a thorough portrayal of the cave.

PLOTTING MAPS EASILY**Computer software**

- Processes raw data quickly.
- Instant maps.
- Examples of software include Compass and SMAPS.

Field method

- Copy data to paper immediately.
 - Slate data difficult to read the next day.
 - Data can be erased or misplaced .
- Convert raw data for the plan view.
 - Raw data is in three dimensions.
 - Corrected data permits a two dimensional cave view.















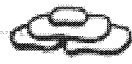









Correcting horizontal measurements

- Use the formula: $\sqrt{S^2 - D^2}$ for the corrected distance for the plan view.
 - S** is the measured distance (horizontal) between survey stations.
 - D** is the change in depth (vertical) between those stations
- Example from Station 2 to Station 3 on above slate*:
 1. Measured distance is 17 feet: Squared value is 289.
 2. Depth change between stations is 10 feet: Squared value is 100.
 3. $289 - 100 = 189$. The square root of 189 is 13.7 feet.
 4. The corrected plan view distance between Station 2 and Station 3 is 13.7 feet.

(*The above example is with data from previous page; "Typical example of slate after a Grade 3 survey".)

TYPICAL UNDERWATER CAVE MAP SYMBOLS

(October 1, 1989)

	Surveyed passage walls.		Dome/pit - floor to ceiling height.
	Explored but unsurveyed.		Direction of flow.
	Underlying passage.		Breakdown.
	Overlying passage.		Limit of daylight - opt. conditions.
	Unexplored passage.		Survey station on line.
	Unexplored passage (too narrow)		Section line - arrow view direction.
	Unexplored passage (too low)		Cross section.
	Water depth at floor.		Penetration - dist. to nearest exit.
	Height, floor to ceiling.		Zero visibility can be expected.
	Slope - splayed down hill.		Silty or silt can be expected.
	Dome - ceiling.		Restriction - major.
	Pit - floor.		Restriction - minor.
	Pit - depth below floor.		
	Dome height above floor.		

Note: These typical underwater cave map symbols from: Basic Underwater Cave Surveying by John Burge. Published by the NSS/CDS, 1988.

CAVERN - BASIC CAVE - **CAVE**

NSS-CDS
Continuing
Education:
Specialty Courses
and Programs

CDS SPECIALTY COURSES and PROGRAMS

Continuing Education: further cave diver training with the NSS-CDS...

Many cave divers look to their NSS-CDS instructor for additional training in specific areas of cave diving. The CDS encourages this level of responsibility and has several specialty areas for this reason. It must be noted that not all CDS Cave Instructors are qualified to teach these specialties. Some of the specialties do not involve in-water training and are academic in nature; these can also be taught by NSS-CDS Program Instructors. Cave divers are encouraged to seek this training, and responsibly ensure themselves the benefits of this experience and training. Information on specialty training is available from cave instructors and on the CDS web site.

STAGE DIVER

This course is intended to help develop the participant's skills and knowledge in extended penetration diving with the use of a stage cylinder. Longer decompression, more complex navigation concerns and cave impacts are covered.

SIDEMOUNT DIVER

This course is designed to expose the experienced cave diver to the cave environment where back-mounted cylinders are not appropriate, or in locations when they are not available. Alternative cylinder and harness configurations are covered and used, and impacts to cave addressed.

DPV PILOT

The purpose of the DPV (Diver Propulsion Vehicle) Pilot specialty course is to expose the trained cave diver to the basic fundamentals of the safe operation of diver propulsion vehicles in underwater caves while under the direct supervision of a qualified DPV Pilot Instructor. The student is able to build practical experience in the field under controlled conditions. Safety practices, procedures and techniques common to most DPV's used in the unique environment of a cave are covered. Conservation considerations such as low-impact operation are emphasized. Potential emergency situations are simulated and practiced.

UNDERWATER CAVE SURVEY DIVER

The purpose of the Basic Survey specialty course is designed to provide the participants with the fundamentals of surveying underwater caves. It is intended to motivate more divers to survey caves, to encourage the use of cave maps in dive planning, and to increase the quantity of published cave maps. Additionally, this course is designed to promote standardization for all survey projects.

(continued next page)

CDS SPECIALTY COURSES and PROGRAMS

UNDERWATER CAVE SURVEY DIVER (CONTINUED)

Topics covered in full detail include: accuracy standards, composition of the survey team, use and fabrication of special tools, survey techniques and methodology, safety considerations, data manipulation and mathematical calculations, symbology, cartography, copyright and publication.

CARTOGRAPHY

This NSS-CDS Special Program is data management-oriented and is designed to introduce the basics of underwater cave map presentations. The program's goal is to develop the ability to complete the surveying and map-making process and produce an actual map.

This program includes a brief review of surveying technique, manual and computer-aided data reduction, verifying data and correcting for errors, necessary materials and supplies, and transforming data into the finished map.

Participation is open to anyone with an interest in underwater cave mapping. Participants are expected to have knowledge of cave diving and underwater surveying. Underwater activities and techniques are discussed in detail; there is no underwater skill training or evaluation.

RECOVERY DIVER

The Recovery Diver Program is a two-part course:

A. Management-oriented session designed to introduce cave divers to the fundamentals of conducting, investigating and managing a cave-diving related fatality and recovery.

B. Field and in-water session covering procedures, techniques, and equipment required for the extraction or rescue of a diver/divers lost in a cave. Divers develop teamwork skills and are educated regarding the responsibilities at the scene of a diving fatality or incident.

Participants receive information on the Recovery Team organization, deployment to an accident scene, interaction with the jurisdictional law enforcement agency and management and techniques of the recovery operation.

CDS SPECIALTY COURSES and PROGRAMS

DEEP CAVE DIVER

This course is meant to further the general development and training of the cave diver. A primary focus in this course is to expand on previously learned skills and to introduce complex navigation, safe execution of complex circuits and/or traverses, decompression theory, oxygen management, accelerated decompression, hypoxic trimix and/or trimix theory, multiple cylinder gas management, and surveying. The use of stage cylinders for extended penetration is introduced. The impacts of advanced techniques relative to cave conservation is discussed. At least two dives are done to familiarize the student with the basics of underwater cave surveying.

OVERHEAD NITROX DIVER

This course introduces participants to the intricacies of planning, collecting and documenting various types of environmental samples. This course will also include cover surveying and the use of the "cave radio" to locate sites at the land surface. It is designed to create a trained group of samplers within the CDS that will be able to assist various state and local agencies in the protection of our water resources and preservation of our underwater caves.

This course is designed to give cave divers a working understanding of proper techniques in environmental sampling of surface water, groundwater, biota, sediment and rocks.

REBREATHER CAVE DIVER

This course introduces participants to the intricacies of planning, collecting and documenting various types of environmental samples. This course will also include cover surveying and the use of the "cave radio" to locate sites at the land surface. It is designed to create a trained group of samplers within the CDS that will be able to assist various state and local agencies in the protection of our water resources and preservation of our underwater caves.

CAVERN - BASIC CAVE - CAVE

NSS-CDS

Appendix

Course	Instructor	Month	Year	A = CAVERN H = INTRO K = CAVE J = APPRENTICE S = STAGE T = SIDEMOUNT F = SURVEYOR E = DPV R = CARTOGRAPHY X = EXTENDED G = OTHER _____	1. PRINT clearly and use a blue/black ballpoint pen only. 2. White copy is to be sent to NSS-CDS Card Processing unless process on-line. 3. Pink copy is issued to student along with temporary card. 4. Yellow copy is for Instructor records.
TRAINING LOCATION					
DATE RECEIVED AT HQ					
INSTRUCTOR USE ONLY					

CAVE DIVING SECTION of the NATIONAL SPELEOLOGICAL SOCIETY, INC.
 2109 W US Hwy 90, Suite 170-317, Lake City, FL 32055

NSS-CDS TRAINING COURSE REGISTRATION

Name: _____ Birth date: (mm/dd/yy) ____/____/____
first middle last

Mailing Address: _____ City: _____

State/Province: _____ Country: _____ Zip/Postal Code: _____

Sex: M () F () Home Phone: () _____ Work Phone: () _____

Cell Phone: () _____ E-mail: _____

My highest level of openwater training is: _____ Agency: _____ Date: _____

Prior overhead environment training (if any) is: _____ Agency: _____ Date: _____

CDS Member (yes or no) _____ NSS Member Number: _____ If not a member, would you like to join: YES () or NO () IF YES:
 Please ask your Instructor for NSS-CDS membership forms. The NSS-CDS membership form and dues can be processed along with this training form.

EMERGENCY CONTACT INFORMATION

In the event that I am unable to respond with contact information, please contact the following person or persons on my behalf.

NAME: _____ PHONE #: _____ RELATIONSHIP: _____

ADDRESS: _____ CITY: _____ STATE: _____ ZIP: _____

NAME: _____ PHONE #: _____ RELATIONSHIP: _____

ADDRESS: _____ CITY: _____ STATE: _____ ZIP: _____

DOCTOR NAME: _____ PHONE #: _____ STATE: _____

MEDICAL INSURANCE CO. _____ POLICY # _____

DIVER INSURANCE: NO, YES, if yes: CO. name: _____ POLICY # _____

Where are you staying during your training: _____ Room # _____ Phone # _____

MEDICAL HISTORY STATEMENT: I understand that cavern and cave diving are strenuous activities involving significant pressure changes and that normal, healthy heart, lungs, ear and sinus, are essential prerequisites for my safety and well-being. I hereby confirm that to the best of my knowledge my circulatory and respiratory systems and body air spaces are healthy and normal and that I have no severe emotional or neurological problems or communicable diseases. I understand that I need to seek unconditional approval for diving from a licensed physician if I am uncertain as to my physical fitness for the rigors of cavern or cave diving.

I have completed the waiver and the medical forms supplied to me by the Instructor. I further understand completion of course and skill performance is determined solely by the Instructor's evaluation of a student's ability, comfort and attitude. Payment of course fees does not guarantee receipt a Training Completion Card.

Signature of Student _____	Signature of Witness _____	Date _____
Signature of Parent or Guardian (when applicable) _____	Witness Name (print) _____	Phone _____
Signature of Parent or Guardian (when applicable) _____	Witness Address (print) _____	City _____ State _____ Zip _____

Instructor Signature: _____ # _____ Date: _____

Name: _____

Instructor Signature: _____ # _____ Date: _____

Name: _____

Rev. 01/05

National Speleological Society - Cave Diving Section
2109 US Hwy 90, Suite 170-317 Lake City, Florida 32055-4703

Assumption of Risk, Liability Release, Waiver & Indemnification Contract

THIS IS A LEGAL DOCUMENT - READ FRONT AND BACK CAREFULLY BEFORE SIGNING!

ASSUMPTION OF RISK: I am a certified scuba diver. I understand diving has the inherent risk of serious personal injury or death. I understand that diving in caverns and cave environments is dangerous. I will be exposed to greater risks which may cause me serious personal injury or death. I am fully aware of the risks of participating in scuba diving, cavern diving and/or cave diving and the associated activities (hereafter called "dive activities" or "activities"). *In consideration of being allowed to participate in dive activities offered by the NSS-CDS, I understand and have carefully evaluated the risk and want to participate despite the risk. By signing this document I hereby agree to expressly and contractually assume all risks associated with all dive activities.* Risk of injury or death may be caused by factors including, but not limited to, lifting and carrying heavy equipment, strenuous activities, dropped or falling objects, collapsing cave structure, forceful currents, becoming disoriented and lost, equipment failures, line traps, line breaks, loss or running out of a breathing gas, quick changes in depth, nitrogen narcosis, incorrect breathing mixtures, and the errors, acts or omissions of myself or others including those affiliated with the NSS-CDS. I understand that the nature and types of possible injuries to me include (but are not limited to) death, barotraumas, decompression sickness, gas embolism, convulsions, unconsciousness, hypothermia, heat stress, back or neck injuries, strained or broken limbs, heart attack, cardiac arrest, stroke, near-drowning and drowning. This list is by no means all inclusive. I understand that I am responsible for my own safety and well being during all diving activities. I understand that it is my responsibility to be physically, medically and mentally fit to participate in diving activities. Should I become ill, injured or uncomfortable in any way, I will immediately advise my instructor and take action to correct my condition and abort the dive. I understand that dive activities are conducted in remote sites (in time and distance) from medical care including a recompression chamber and I accept these risks and still choose to participate. I agree that I should have personal dive accident insurance and represent that I either have it or choose to participate without it. By signing this agreement, I hereby agree, on behalf of myself and my heirs, to assume all risks associated with diving activities, including the risk of serious personal injury and death, whether foreseen or unforeseen.

LIABILITY RELEASE: By signing this contract I am hereby giving up the legal right to sue the National Speleological Society- Cave Diving Section (NSS-CDS), its owners, officers and directors, employees, agents, operators, volunteers, instructors, their affiliated dive centers and dive sites, their insurance companies, land owners, third parties or anyone else specifically named or unnamed (hereafter called "released parties") as a result of my or anyone else's injury or death resulting from my diving activities associated with NSS-CDS training. *In consideration of being allowed to participate in diving activities with the NSS-CDS and released parties, I hereby agree to give up my right to sue and I hereby release the aforementioned parties from any liability in connection with the diving activities which may result in injury or wrongful death including, but not limited to, property damage, injury, or wrongful death caused to me or any others due to negligence caused by errors, acts or omissions of myself or others.* I hereby give up these valuable legal rights on behalf of myself, my estate, family, heirs, assigns or any other party that may have a legal claim against the released parties. I agree it is my exclusive responsibility to educate my family of the risks associated with my participation in diving activities. I have made my family fully aware of the risks of these dive activities.

WAIVER & INDEMNIFICATION: By signing this document I hereby waive all claims arising by me, my family, heirs, assigns or any other party who may have a claim against the released parties as a result of my participation in the diving activities. Furthermore, I agree to indemnify and hold harmless the released parties for any responsibility or liability for any loss, costs, attorneys fees, liabilities, damages, injury or death arising from my participation in the diving activities with the released parties.

Go to other side to complete and sign →

National Speleological Society - Cave Diving Section
 2109 US Hwy 90, Suite 170-317 Lake City, Florida 32055-4703

Assumption of Risk, Liability Release, Waiver & Indemnification Contract
(Continued from front page)

(WAIVER & INDEMNIFICATION: (continued)) *It is my specific contract, by signing this document, that I will not present a claim, cause of action, lawsuit or other action for any damage, injury or death caused to me or any other party including minor children for whom I may have a legal right in connection with any dive activities associated with the released parties. In the event I violate this contract I agree to be held responsible and liable for all damages, expenses, fees and cost associated with released parties defending and or paying claims brought on my behalf and I make this contract on behalf of my heirs as well. In the event I cause released parties damage or expense associated with my participation in the activities, I agree to be responsible and liable for same and will agree to pay as if fully adjudicated by a competent court.*

CONTRACTUAL AGREEMENT: *I understand that this is a legally binding contract and that I have signed this contract of my own free will. By signing it, I hereby agree to all of its terms and conditions. I have read it thoroughly before signing it. If I do not understand any of the provisions, I understand that it is my responsibility to get clarification of everything I did not understand before signing this contract. I am legally competent and over the age of 18 years old or I have obtained the signature of my parent or guardian, and despite my age, I agree to be bound by the direction, control and authorization of my parent or guardian who has also signed this document. I agree that I will not hold the released parties under any obligation, responsibility or liability to provide me with emergency response, rescue, first aid, medical care, emergency transportation, or recovery of the participant. I agree that before each dive I will inspect all of my equipment to verify I take everything that I will need on the dive, that I know my gas mixes and the limitations of each, and that my equipment is in proper functioning order. I hereby agree to all of the terms, conditions and provisions of this agreement without modification from its preprinted form. I agree that if any provision of this document is found to be void or unlawful that the remainder of the contract shall remain in full force and effect. In the event a legal determination is required, I agree to be bound by the laws of the State of Florida.*

By signing this document I represent that I have read, understand and agree to be legally bound by all of the provisions of this contract.

Date _____ Course _____ Instructor _____

Participant's Name (Print) _____

Participant's Signature _____

Witness's Name (Print) _____

Witness's Signature _____

If the participant is under the age of 18, then the parent or guardian must sign this contract and agree to be legally bound by it and furthermore be legally responsible for the minor participant, including being responsible for all damage, injury or death which may occur as a result of the minor's participation in diving activities. The parent or guardian's hereby agrees to be fully responsibility to the released parties for any damage, injury or death caused by the minor, including actions brought by the minor, for any damages whatsoever.

Parent or Guardian Name (print) _____

Parent or Guardian's Signature _____



MEDICAL STATEMENT

Participant Record (Confidential Information)

Please read carefully before signing.

This is a statement in which you are informed of some potential risks involved in scuba diving and of the conduct required of you during the scuba training program. Your signature on this statement is required for you to participate in the scuba training program offered.

by _____ and
Instructor

Facility

Read and discuss this statement prior to signing it. You must complete this Medical Statement, which includes the medical history section, to enroll in the scuba training program. If you are a minor, you must have this Statement signed by a parent.

Diving is an exciting and demanding activity. When performed correctly, applying correct techniques, it is very safe. When established safety procedures are not followed, however, there are dangers.

To scuba dive safely, you must not be extremely overweight or out of condition. Diving can be strenuous under certain conditions. Your respiratory and circulatory systems must be in good health. All body air spaces must be normal and healthy. A person with heart trouble, a current cold or congestion, epilepsy, asthma, a severe medical problem, or who is under the influence of alcohol or drugs should not dive. If taking medication, consult your doctor and the instructor before participation in this program. You will also need to learn from the instructor the important safety rules regarding breathing and equalization while scuba diving. Improper use of scuba equipment can result in serious injury. You must be thoroughly instructed in its use under direct supervision of a qualified instructor to use it safely.

If you have any additional questions regarding this Medical Statement or the Medical History section, review them with your instructor before signing.

MEDICAL HISTORY

To the Participant:

The purpose of this medical questionnaire is to find out if you should be examined by your doctor before participating in recreational diver training. A positive response to a question does not necessarily disqualify you from diving. A positive response means that there is a preexisting condition that may affect your safety while diving and you must seek the advice of your physician.

Please answer the following questions on your past or present medical history with a YES or NO. If you are not sure, answer YES. If any of these items apply to you, we must request that you consult with a physician prior to participating in scuba diving. Your instructor will supply you with a Medical Statement and Guidelines for Recreational Scuba Diver's Physical Examination to take to your physician.

- _____ Could you be pregnant or are you attempting to become pregnant?
- _____ Do you regularly take prescription or nonprescription medications? (with the exception of birth control)
- _____ Are you over 45 years of age and have one or more of the following?
 - currently smoke a pipe, cigars, or cigarettes
 - have a high cholesterol level
 - have a family history of heart attacks or strokes

- _____ History of diving accidents or decompression sickness?
- _____ History of recurrent back problems?
- _____ History of back surgery?
- _____ History of diabetes?
- _____ History of back, arm or leg problems following surgery, injury or fracture?
- _____ Inability to perform moderate exercise (example: walk one mile within 12 minutes)?
- _____ History of high blood pressure or take medicine to control blood pressure?
- _____ History of any heart disease?
- _____ History of heart attacks?
- _____ Angina or heart surgery or blood vessel surgery?
- _____ History of ear or sinus surgery?
- _____ History of ear disease, hearing loss or problems with balance?
- _____ History of problems equalizing (popping) ears with airplane or mountain travel?
- _____ History of bleeding or other blood disorders?
- _____ History of any type of hernia?
- _____ History of ulcers or ulcer surgery?
- _____ History of colostomy?
- _____ History of drug or alcohol abuse?

Have you ever had or do you currently have . . .

- _____ Asthma, or wheezing with breathing, or wheezing with exercise?
- _____ Frequent or severe attacks of hayfever or allergy?
- _____ Frequent colds, sinusitis or bronchitis?
- _____ Any form of lung disease?
- _____ Pneumothorax (collapsed lung)?
- _____ History of chest surgery?
- _____ Claustrophobia or agoraphobia (fear of closed or open spaces)?
- _____ Behavioral health problems?
- _____ Epilepsy, seizures, convulsions or take medications to prevent them?
- _____ Recurring migraine headaches or take medications to prevent them?
- _____ History of blackouts or fainting (partial loss of consciousness)?
- _____ Do you frequently suffer from motion sickness (seasick, carsick, etc.)?

The information I have provided about my medical history is accurate to the best of my knowledge.

Participant's Signature

Date (day/month/year)

Signatures of Parent or Guardian (where applicable)

Date (day/month/year)

DISSIMILAR TANK CONVERSION

1. DETERMINE WORKING PRESSURE OF TANK

Sherwood pressed steel:	104 @ 2400+ psi = 2640 psi = 104 cu. ft.
Genesis 120-:	120 @ 3500 psi = 120 cu. ft.
Genesis 100:	100 @ 3500 psi = 100 cu. ft.
Scubapro 95:	95 @ 2400+.psi = 2640 psi = 95 cu. ft.
Aluminum 80:	80 @ 3000 psi = 80 cu. ft.
Steel 72:	72 @ 2250+ psi = 2475 psi = 72 cu. ft.

2. DIVIDE THE RATED VOLUME OF THE TANK BY THE RATED PRESSURE OF THE TANK AND MULTIPLY BY 100 FOR CUBIC FEET PER 100 PSI OF TANK PRESSURE.

- The working pressure for steel tanks must include the 10 % overfill.
- Double the volume for two tanks.

Sherwood PST 104:	$104 / 2640 = .039 \times 100 = 3.9$ cu. ft./100 psi (7.8 cu. ft./doubles)
Genesis 120:	$120 / 3500 = .034 \times 100 = 3.4$ cu. ft./100 psi (6.8 cu. ft./doubles)
Genesis 100:	$100 / 3500 = .028 \times 100 = 2.8$ cu. ft./100 psi (5.6 cu. ft./doubles)
Scubapro 95:	$95 / 2640 = .036 \times 100 = 3.6$ cu. ft./100 psi (7.2 cu. ft./doubles)
Aluminum 80:	$80 / 3000 = .027 \times 100 = 2.7$ cu. ft./100 psi (5.4 cu. ft./doubles)
Steel 72:	$72 / 2475 = .029 \times 100 = 2.9$ cu. ft./100 psi (5.8 cu. ft./doubles)

BASELINE FOR VARIOUS TANKS (per 100 psi)

Sherwood PST 104:	3.9 / 7.8 cu. ft.	Aluminum 80:	2.7 / 5.4 cu. ft.
Genesis 120:	3.4 / 6.8 cu. ft.	Steel 72:	2.9 / 5.8 cu. ft.
Genesis 100:	2.8 / 5.6 cu. ft.	Scubapro 95:	3.6 / 7.2 cu. ft.

3. DETERMINE CRITICAL AIR SUPPLY OF EACH DIVER.

EXAMPLE: Diver A has double aluminum 80's with 3000 psi
 Diver B has double steel 104's with 3000 psi

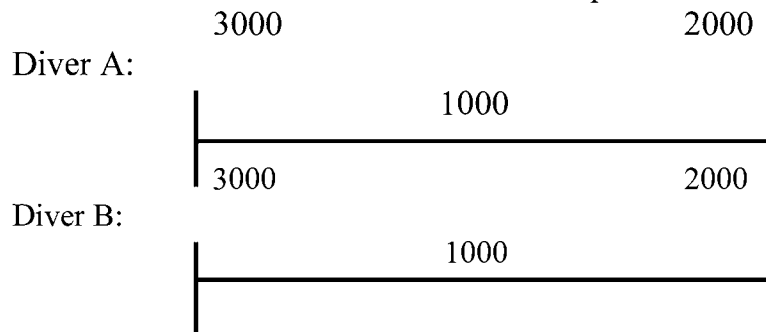

4. CONVERT PSI (PRESSURE) TO CUBIC FEET (VOLUME)

Baseline X # of 100's of usable psi = cu. ft.

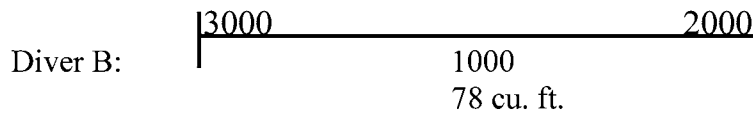

(**What problems may result from not calculating dissimilar tanks? How does this relate to the problems which may arise in not computing dissimilar pressures?)

5. DETERMINE THE VOLUME LIMITATIONS OF THE DIVE TEAM.

Having determined the lower volume, each diver is limited to that volume. In our example, both divers must use only 54 cu. ft. of air on this dive. 54 cu. ft. is the same volume of air whether it comes out of the 80's or 104 's. The diver with the larger tanks - Diver B - must convert usable volume (expressed in cu. ft.) to usable pressure (expressed in p.s.i).

To convert cubic feet to psi, divide the usable cubic feet of the smaller tank by the baseline of the larger cylinder and multiply the result by 100.

Example: $54 \text{ (usable cu. ft. of 80's)} / 7.8 \text{ (baseline of 104 's)} = 6.92 \times 100 = 692$
 Diver B has 692 psi of usable air of this dive.

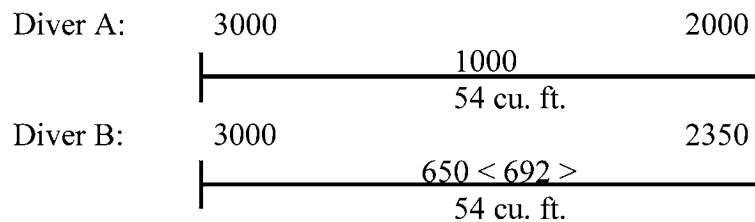

ALTERNATE METHOD

By applying the baseline of each tank, the divers may arrive at a percentage to use in pre-planning ending pressures for each tank-set of tanks.

EXAMPLE:

Double 95: 7.2 baseline Double 104: 7.8 baseline
 $7.2 / 7.8 = .9113$ or 91%

Fill the 104's to 3600 psi and the 95's to 3276 psi (91 % of 3600).

Cow Spring

Cave System
Suwannee County, Fl.

Total survey 3215'
All passages underwater
Cartography by Wes C. Skiles
Survey by the Cave Diving Section of the
National Speleological Society
NSS/CDS Exploration and Survey Team:
Lester Hires, Woody Jasper, Tom Morris, Wes Skiles

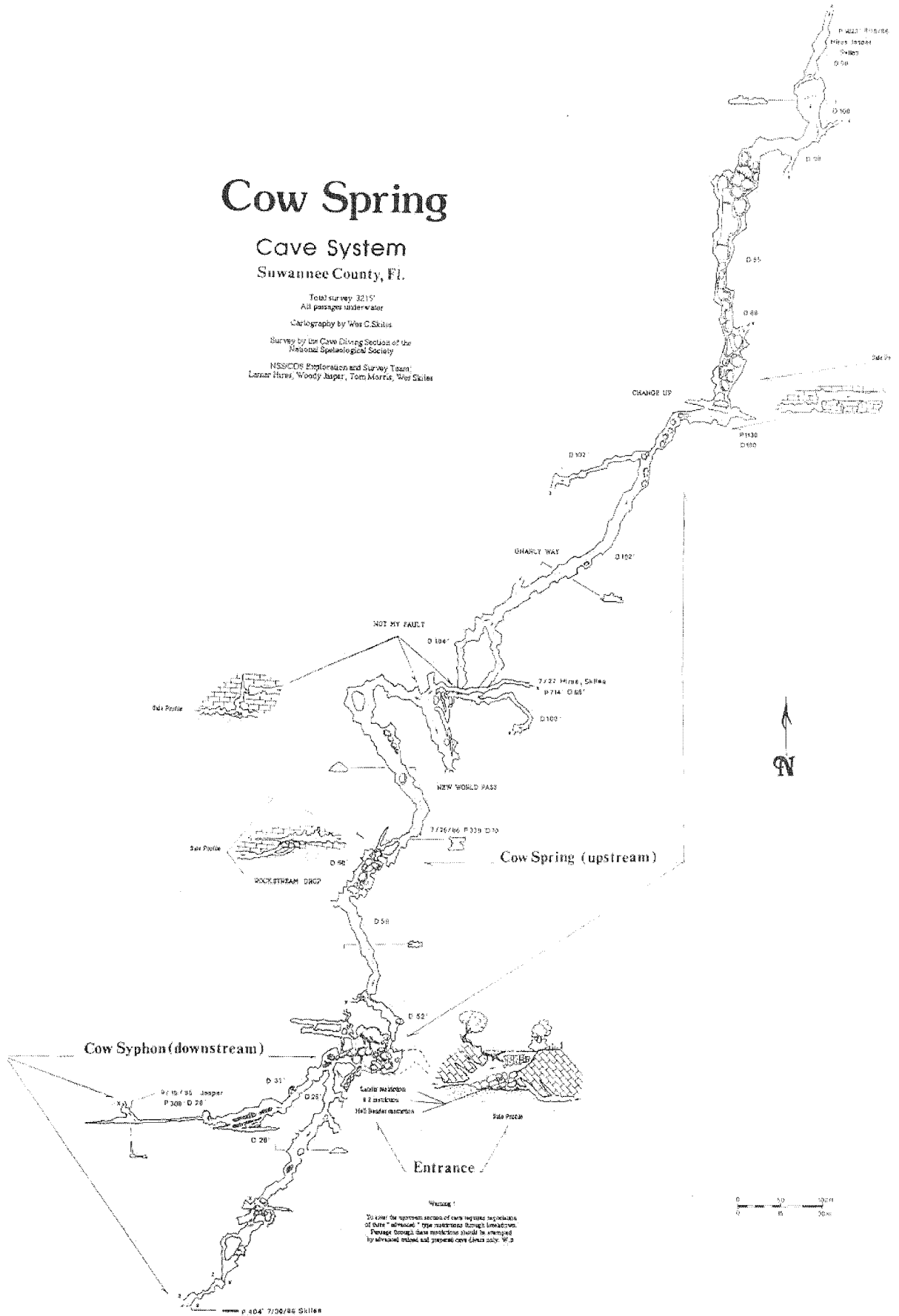



PEACOCK SPRINGS CAVE SYSTEM

PEACOCK SPRINGS STATE PARK, SUWANNEE COUNTY, FLORIDA

COPYRIGHT 1986 MICHAEL POLK WITH TONY PAIE

SURVEYED BY: TONY PAIE, BILL BENNARD, TED COLE, SCOTT WORRELL

DENNIS HOLDEN, MICHAEL POUCHER

SPECIAL THANKS: BRUCE CAMPBELL, STEVE GERRARD, BRUCE POLK III, JOHN GRIEWSKI, ARNOLD JACKSON, JOHN DUNK, TOM McDONALD, BRUCE DUCKSWORTH, ANNOTE GEBUS, JULIUS EDMISTIS, JUDY JACSON, KERRY DUFFY, QUENTIN JONES, WAYNE BRAD, STEVE GREENE, PAUL LOGAN, ELINA CASSON, STEPHAN LEE

ORIGINAL DATA BY: S. EMLEY, L. HOLZENDORF, K. HILLER, B. JOHNSON, C. SMITH, J. ZEMBRICK

SPONSORS: DIVERITE MANUFACTURING, THE DIVE OUTPOST, CAVE EXCURSIONS, AMERICAN UNDERWATER LIGHTING

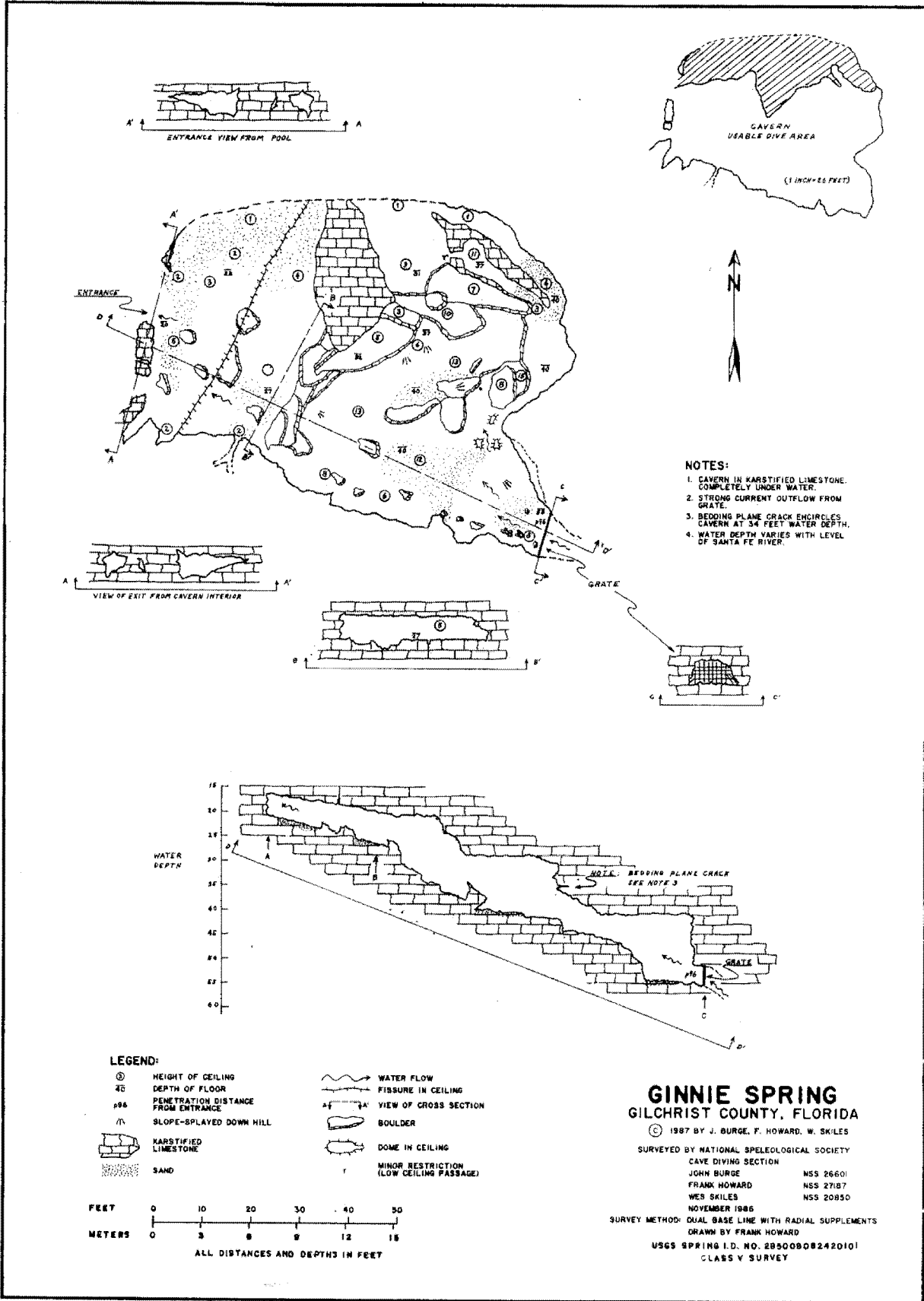

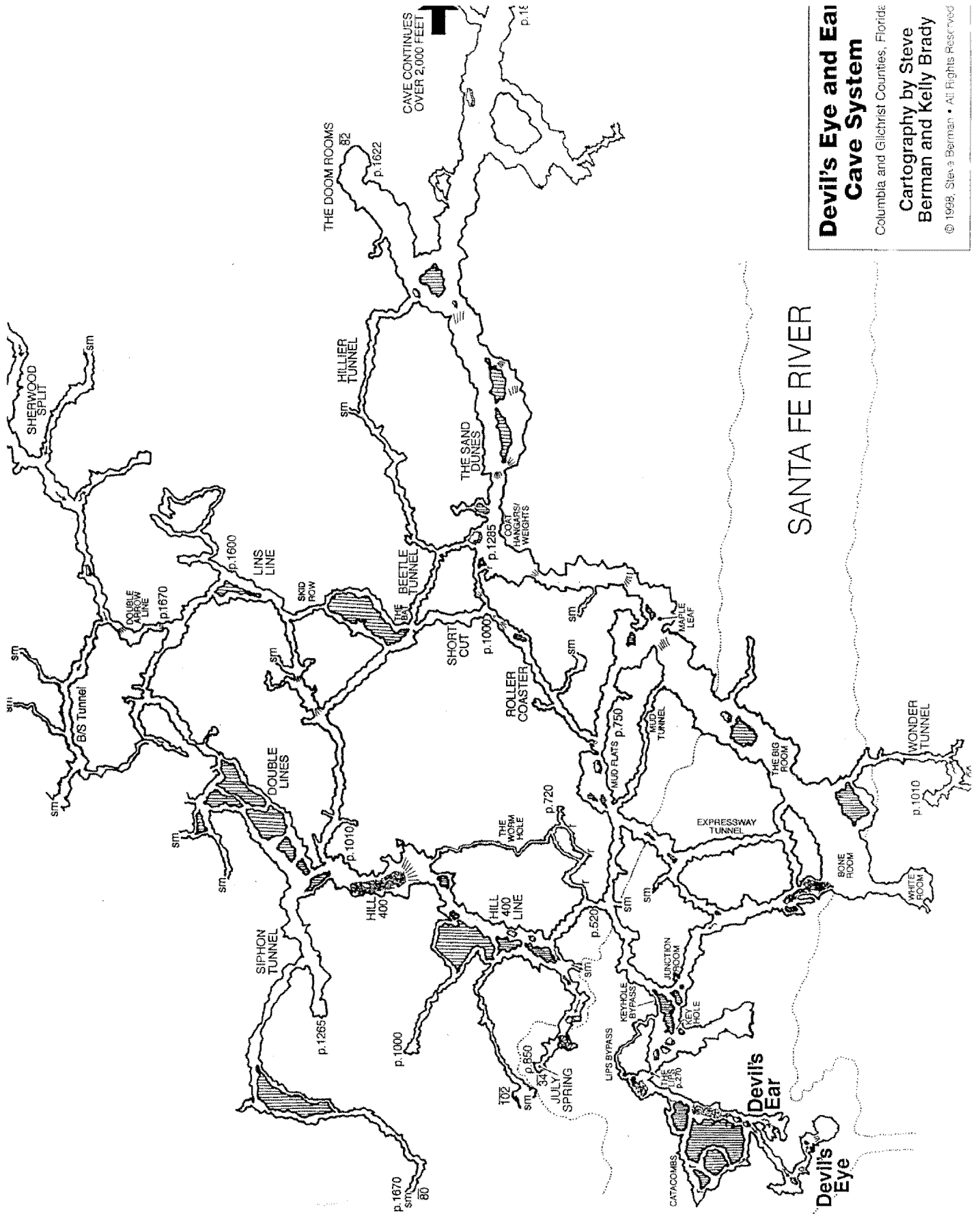

Devil's Eye and Eai Cave System
 Cartography by Steve Berman and Kelly Brady
 © 1998, Steve Berman • All Rights Reserved

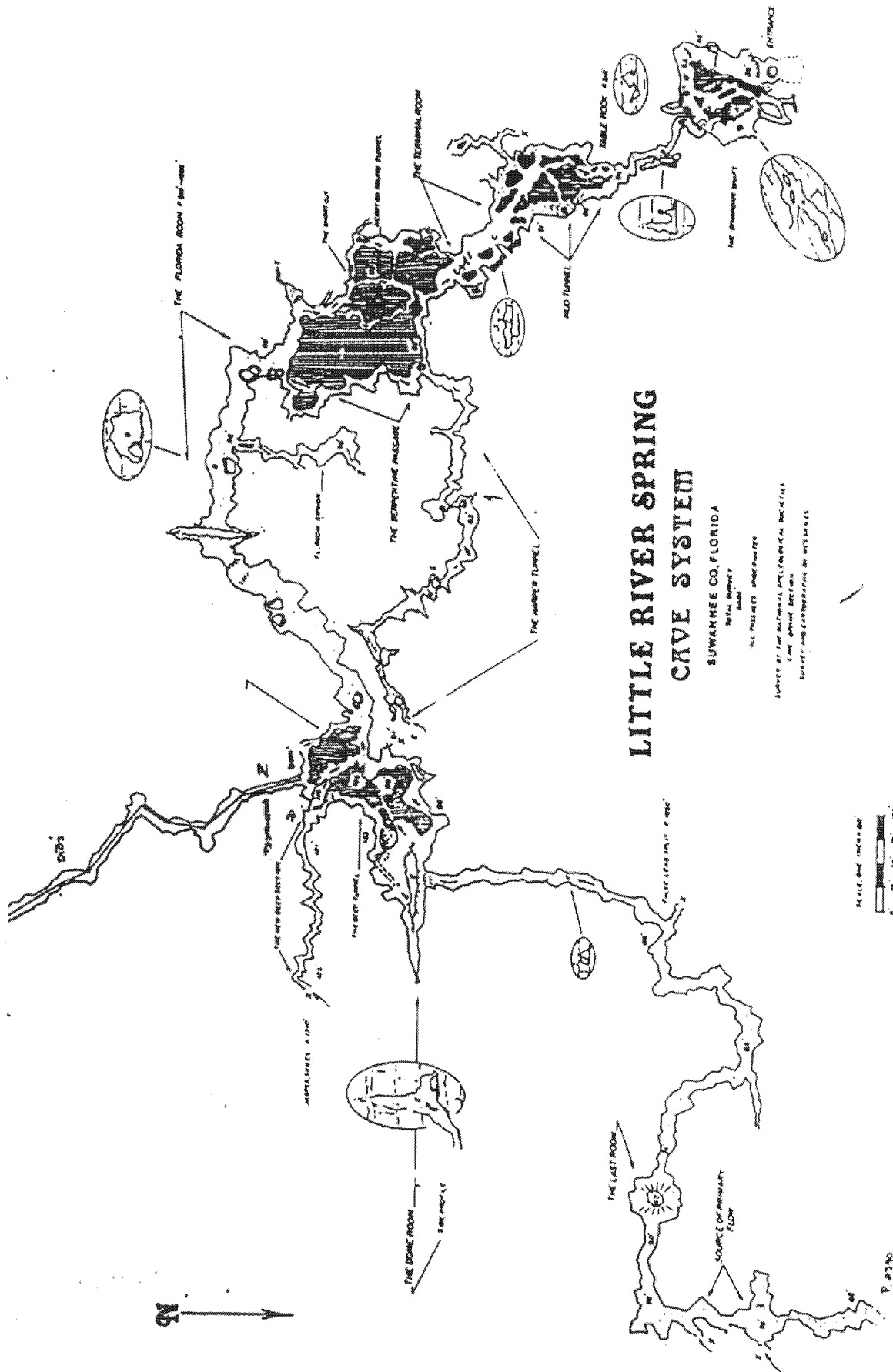

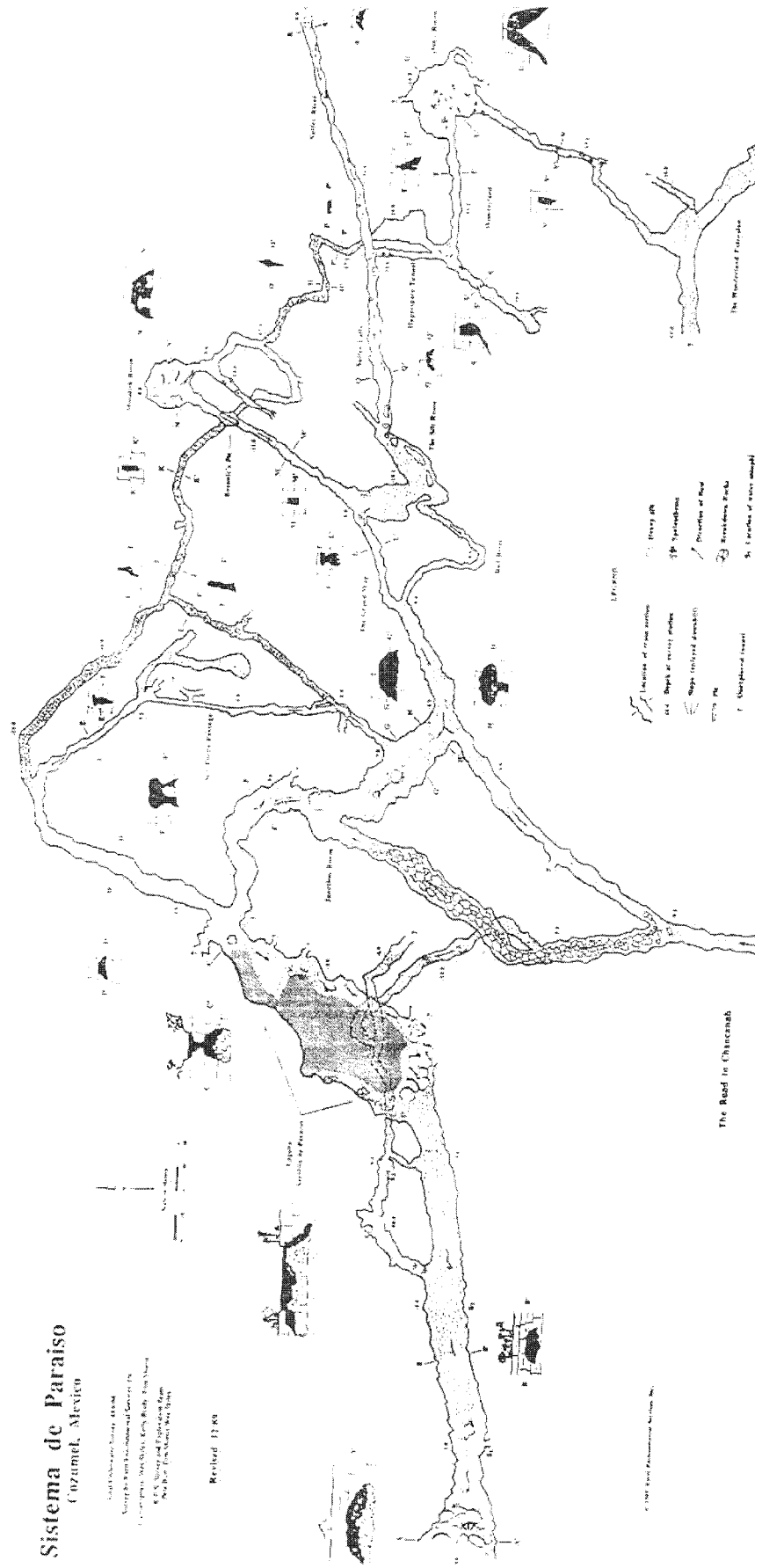

Sistema de Paraiso
Cozumel, Mexico

Copyright © 2008, National Geographic Society
 All rights reserved. No part of this publication may be reproduced, stored in a retrieval system, or transmitted, in any form or by any means, without the prior written permission of National Geographic Society.

Revised: 11/08

© 2008 National Geographic Society, Inc.

NOTES

In the present tropical epoch, this freshwater cave is completely underwater. It channels fresh water from a large inland karst area through fossil sea gaps. Typical environmental conditions include black 78° fahrenheit water and 100% humidity. A bathymetric survey was normally conducted at a depth of 60 feet (18 meters). Only trained individuals with proper equipment should enter this cave and fragile cave systems.

A specific compass and bearing have been used to confirm all azimuths and distances, except where noted as limited free survey (LFS). A bathymetric survey was incorporated beyond the LFS symbol appearing on the map plan. A precision depth gauge (1/8 inch accuracy) was used to measure water depths. All distances have been corrected for the plus view. Penetration (i.e., p. 3000) from the entrance and the depth have been recorded in feet. Because of the variable nature of the cave system, the survey depicts the major features of the cave passages.

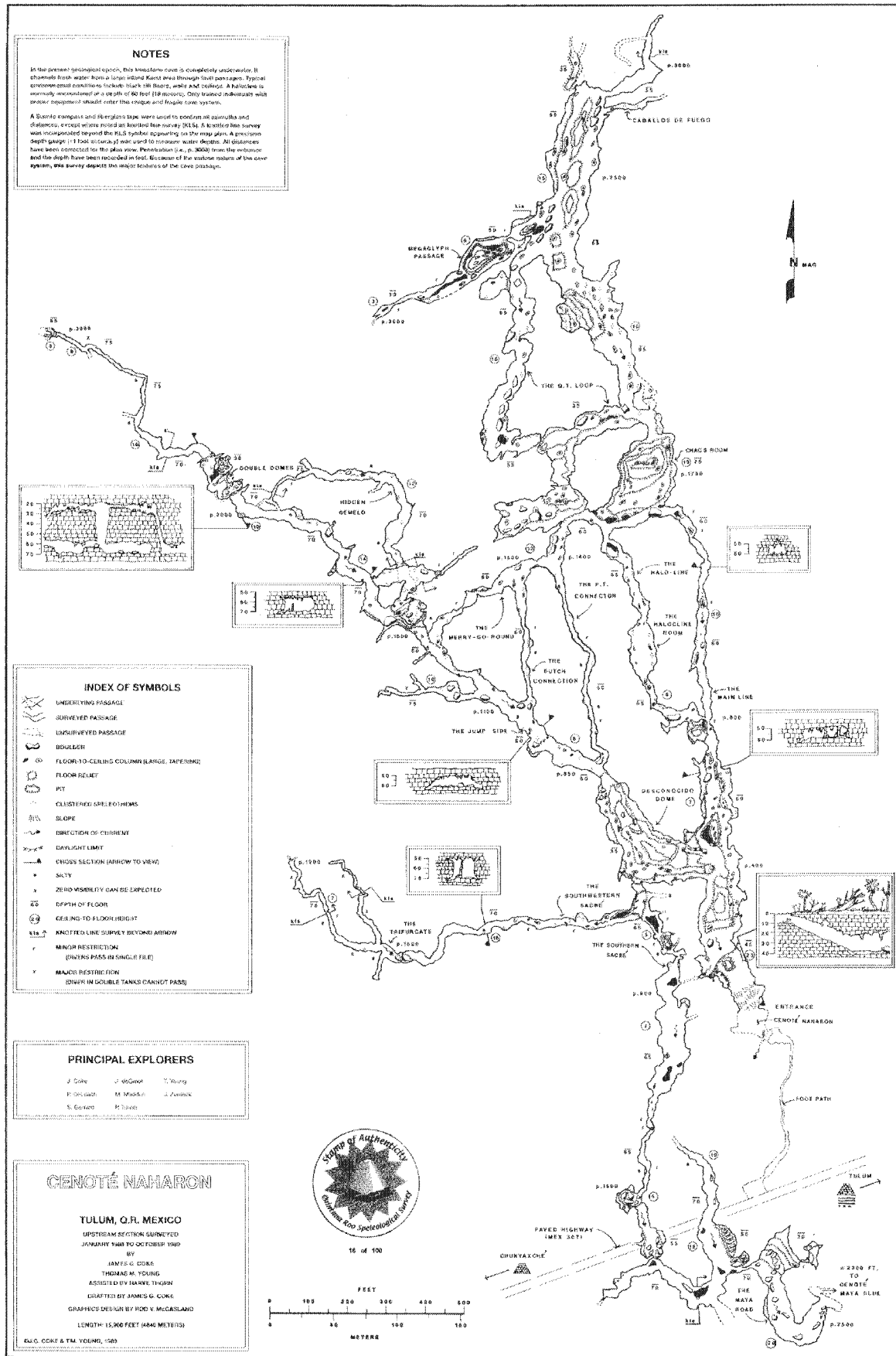

INDEX OF SYMBOLS

- UNDERLYING PASSAGE
- SURVEYED PASSAGE
- UNSURVEYED PASSAGE
- BOULDER
- FLOOR-TO-CEILING COLUMN (LARGE, IMPERIOUS)
- FLOOR RELIEF
- PIT
- CLEFTED SPHERULITES
- SLOPE
- DIRECTION OF CURRENT
- DAYLIGHT LIMIT
- CROSS SECTION (ARROW TO VIEW)
- SALTY
- ZERO VISIBILITY CAN BE EXPLOITED
- DEPTH OF FLOOR
- CEILING TO FLOOR HEIGHT
- KNOTTED LINE (SURVEY BEYOND ARROW)
- MANIC RESTRICTION (DRINKS PASS IN SINGLE FILE)
- MANIC RESTRICTION (DIVER IN DOUBLE TANKS CANNOT PASS)

PRINCIPAL EXPLORERS

- J. Cook J. G. Cook T. Young
- F. Cook M. Madril J. Zwick
- S. Cook R. T. Cook

CENOTE NAHARON

TULUM, Q.R., MEXICO
 UPSTREAM SECTION SURVEYED
 JANUARY 1988 TO OCTOBER 1989
 BY
 JAMES G. COOK
 THOMAS M. YOUNG
 ASSISTED BY HARVEY THORNTON
 DRAFTED BY JAMES G. COOK
 GRAPHICS DESIGN BY ROD V. MCGANLAND
 LENGTH 15,360 FEET (4646 METERS)
 ©1990 CDSR & T.M. VOLANI, 1989

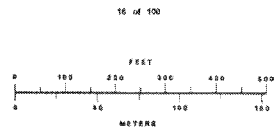

CENOTÉ GARWASH

TULUM, Q. ROO MEXICO
SURVEYED
OCTOBER 1986 TO AUGUST 1989

JAMES G. COKE IV
JOHANNA DE GROOT
EDWARD S. YOUNG
JAMES G. COKE IV

1087 METERS LENGTH, 383 FEET (117.2 METERS)
DOWNSTREAM LENGTH 383 FEET (117.2 METERS)

© J.G. COKE & E.M. YOUNG, 1989

NOTES

In this project geologists, archaeologists, and cave divers have been working together to explore the cenote system. The project has been a success in many ways. It has provided a detailed map of the cenote system, which will be useful to future explorers. It has also provided a detailed record of the cave system, which will be useful to future researchers. The project has been a success in many ways. It has provided a detailed map of the cenote system, which will be useful to future explorers. It has also provided a detailed record of the cave system, which will be useful to future researchers.

PRINCIPAL EXPLORERS

- J. Coke
- B. A. Madsen
- P. Baker
- T. Young

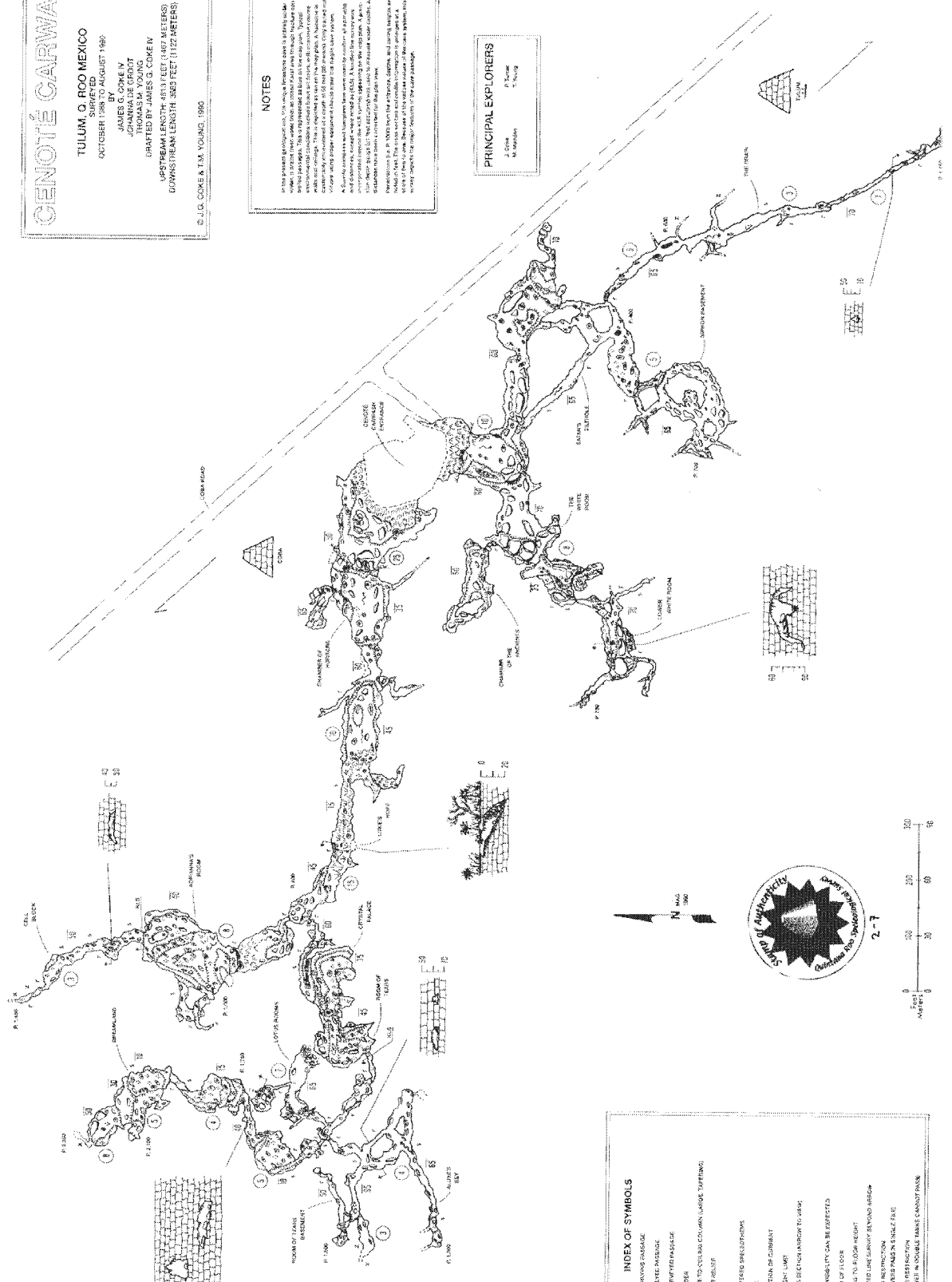

INDEX OF SYMBOLS

	UNKNOWN PASSAGE
	SURVEYED PASSAGE
	UNSURVEYED PASSAGE
	CHAMBER
	POOL
	SHAFT
	FLOOR LEVEL
	CLUSTERED SPELEOTHEMS
	SAGAN
	DIRECTION OF CURRENT
	DAYLIGHT LIMIT
	GATEWAY SECTION
	SAFETY
	ZERO VISIBILITY CAN BE DETECTED
	DEPTH OF FLOOR
	CEILING TO FLOOR HEIGHT
	KNOTTED LINE SURVEY BEYOND ARROW
	MINOR RESTRICTION
	MAJOR RESTRICTION
	MULTIPLE PASSAGE
	CAVE IN DOUBLE BANK CANYON DRAIN

